

Bauanleitung / Assembly manual – Panzer I Ausf. B (Sd.Kfz.101)

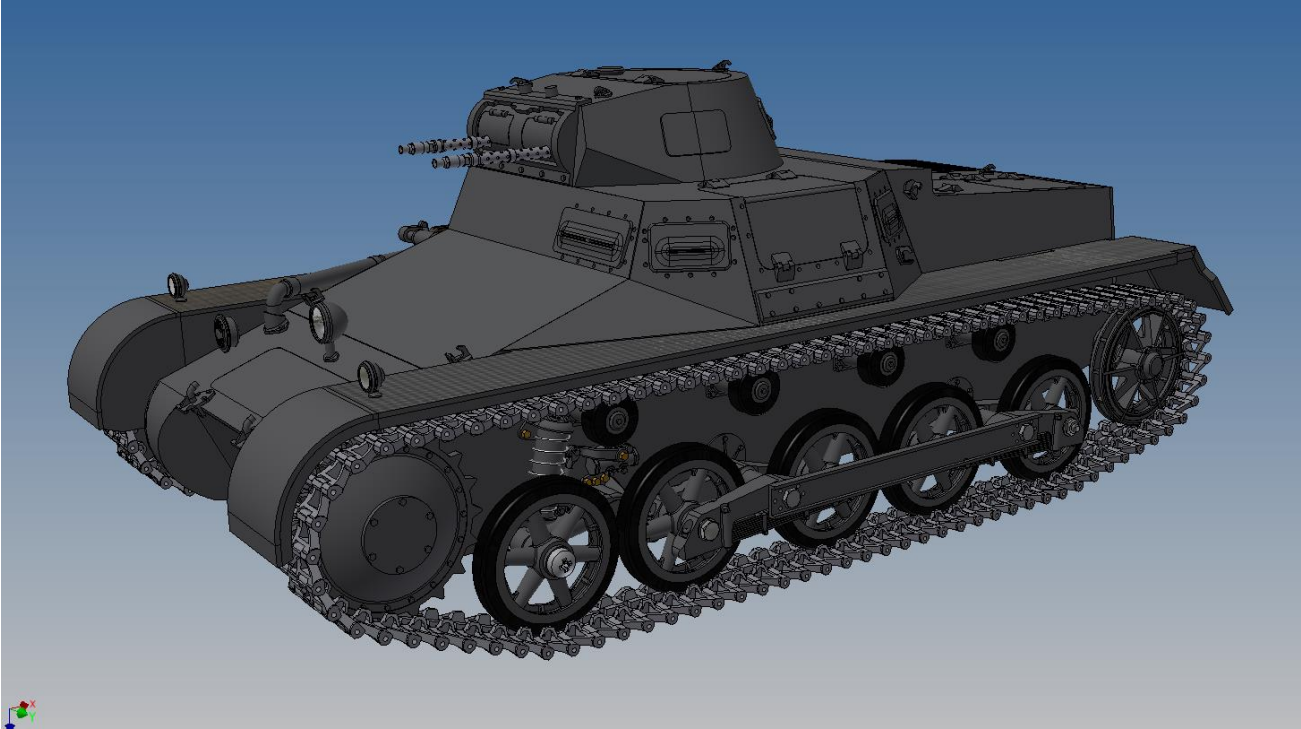

Unterwanne / lower hull

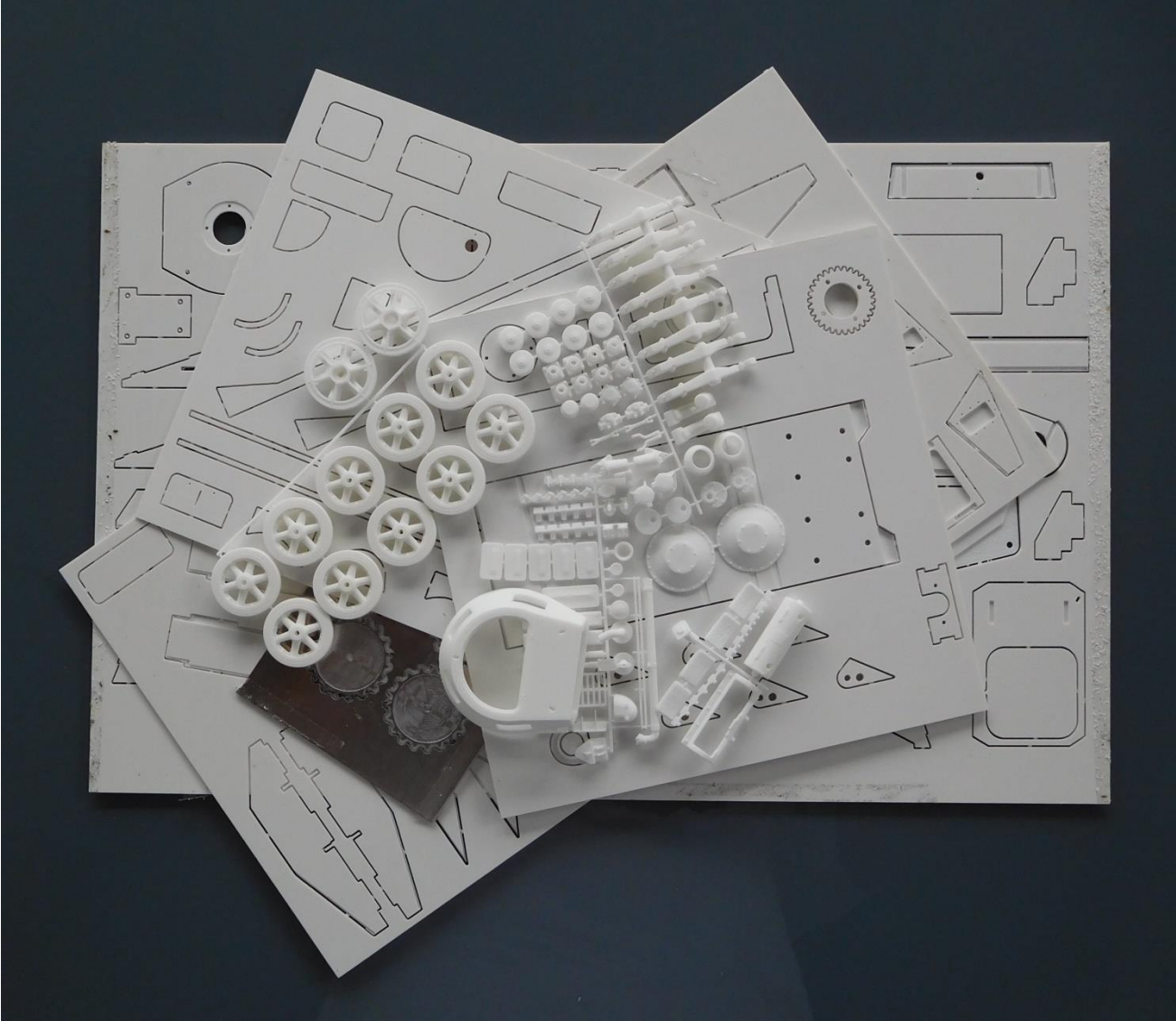
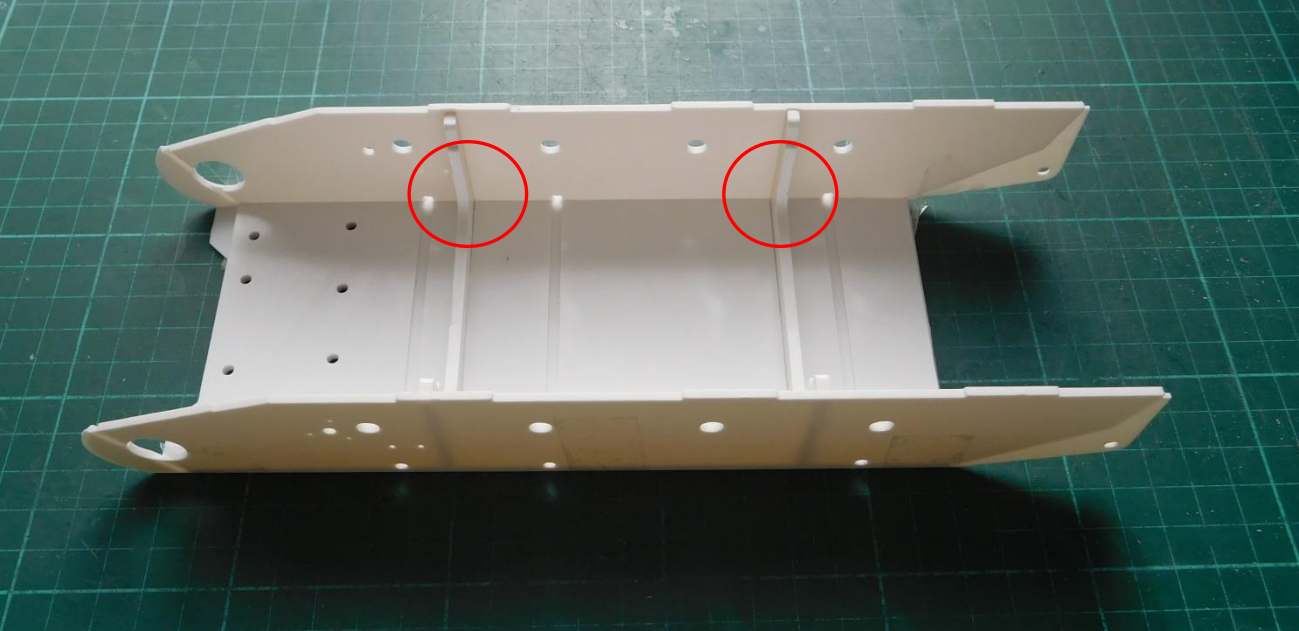
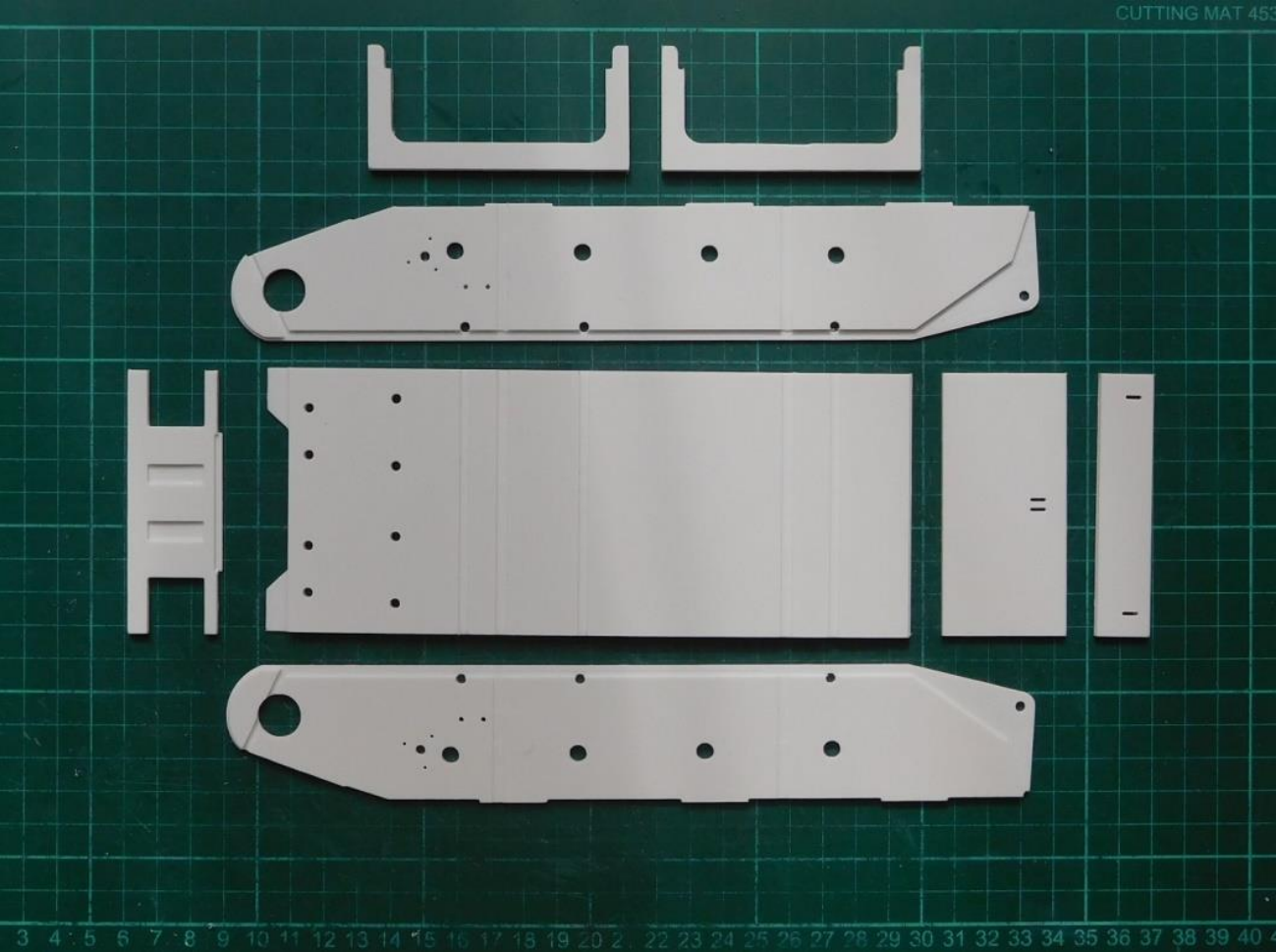

Oberflächen bündig /
surfaces should match

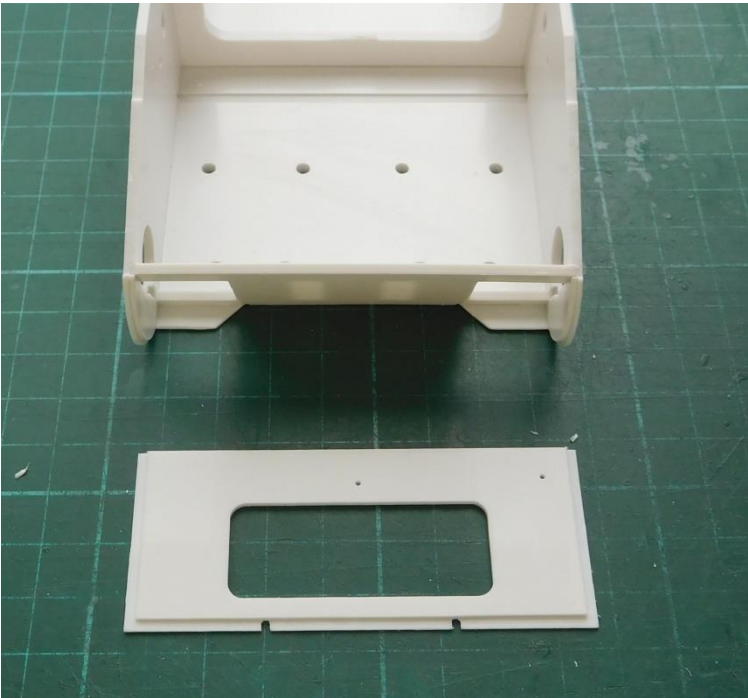
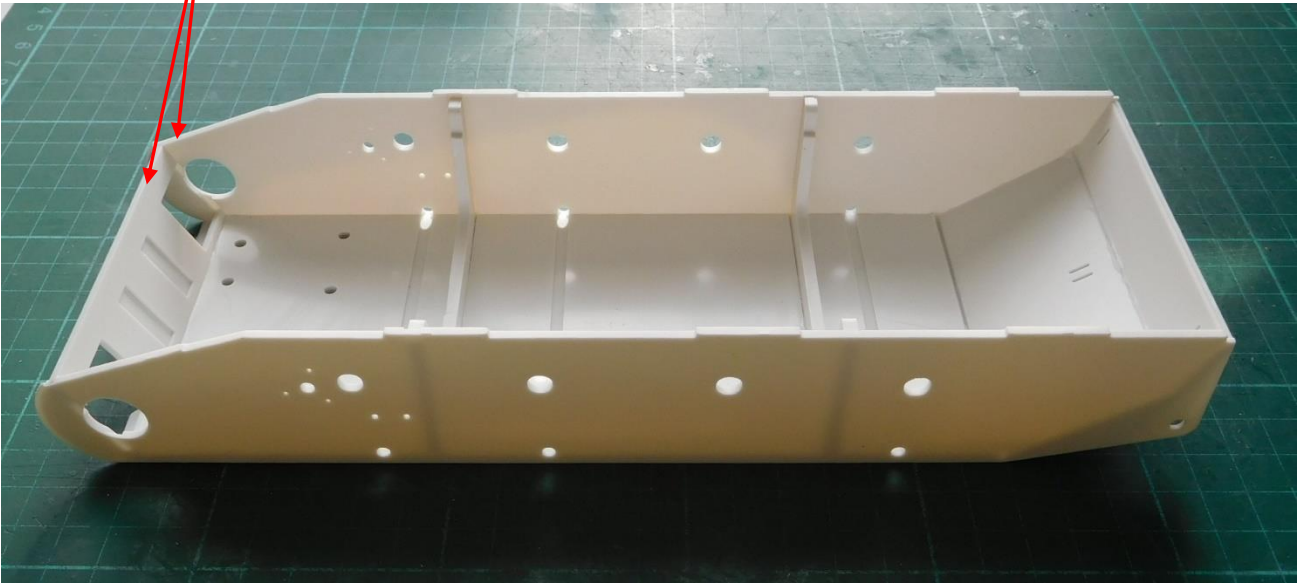

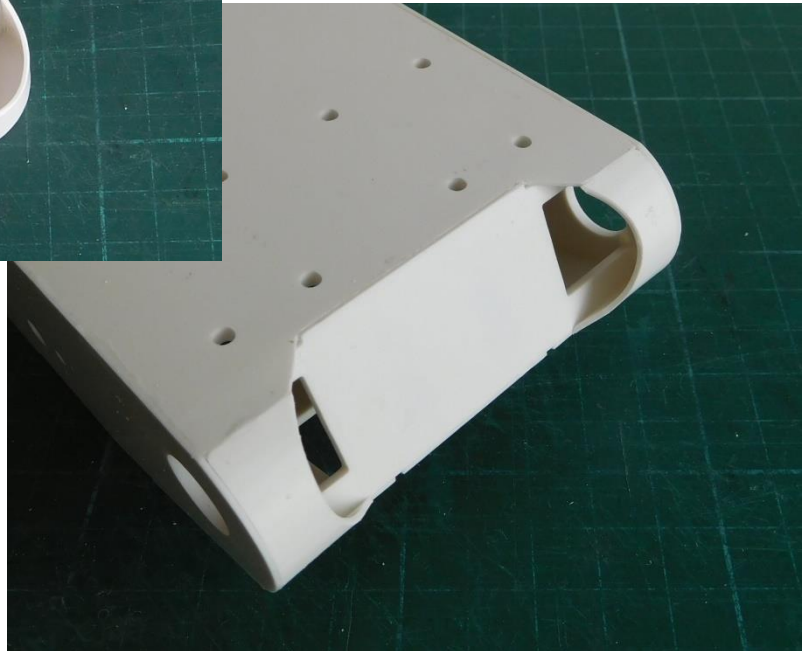

Fase / beveling

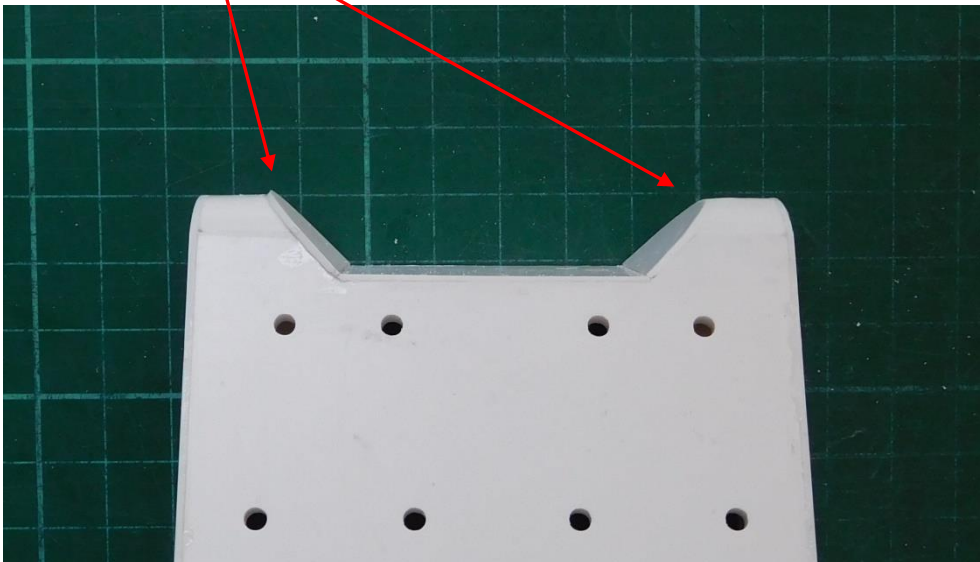
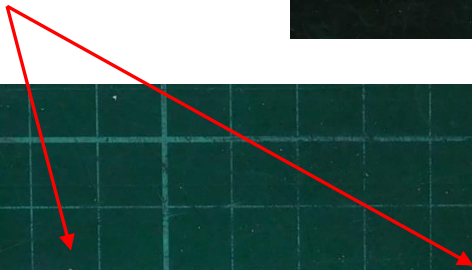

Laufwerk / suspension

Messing-Rohr / brass pipe
Ø3.0/Ø2.1x128mm

Messing-Rohr / brass pipe
Ø3.0/Ø2.1x16mm

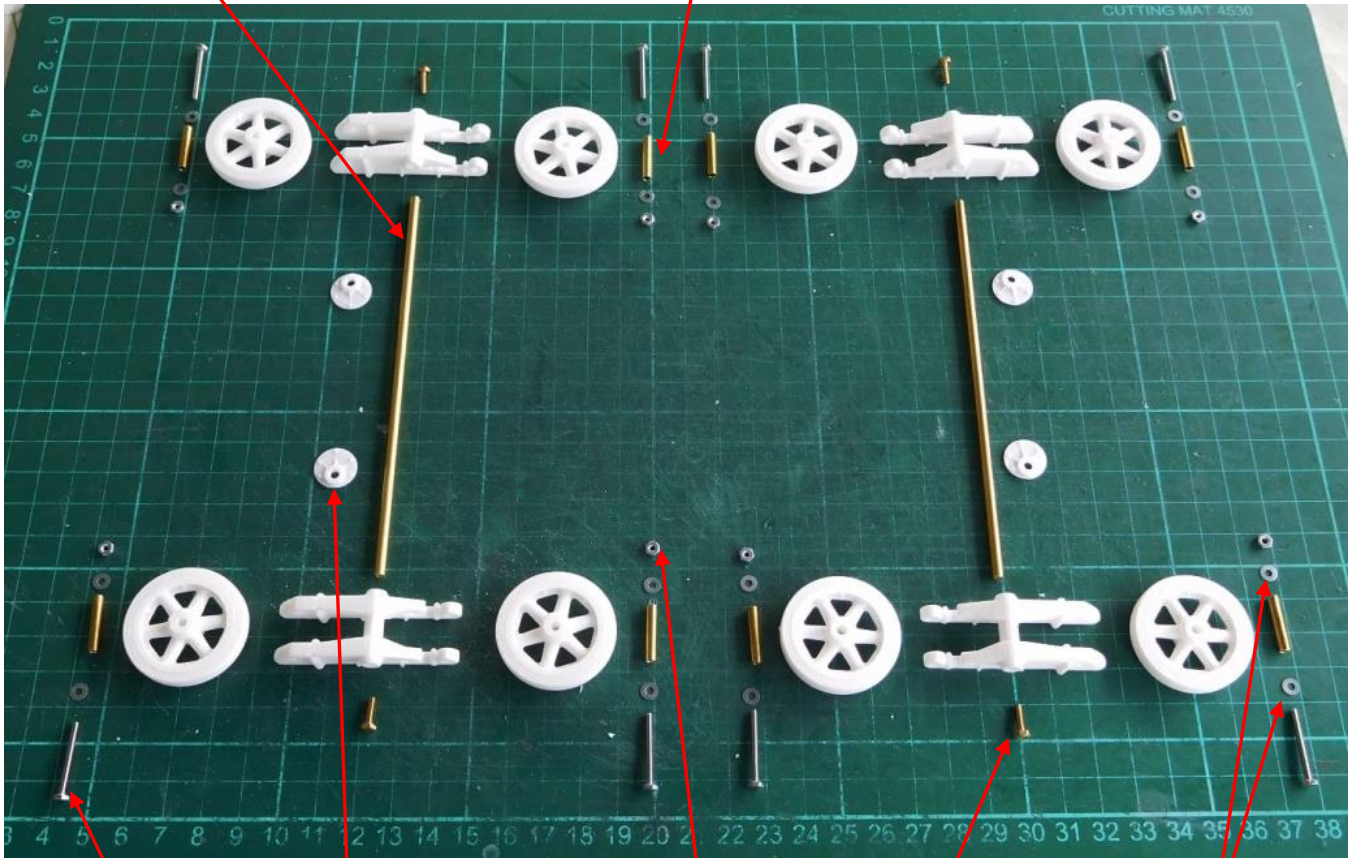

6kt-Schraube / hex.
screw M2x20

Achsflansch / axis
flange 3D printed

Mutter / nut M2

6kt-Schraube / hex.
screw M2x6

U-Scheibe für M2 /
washer M2

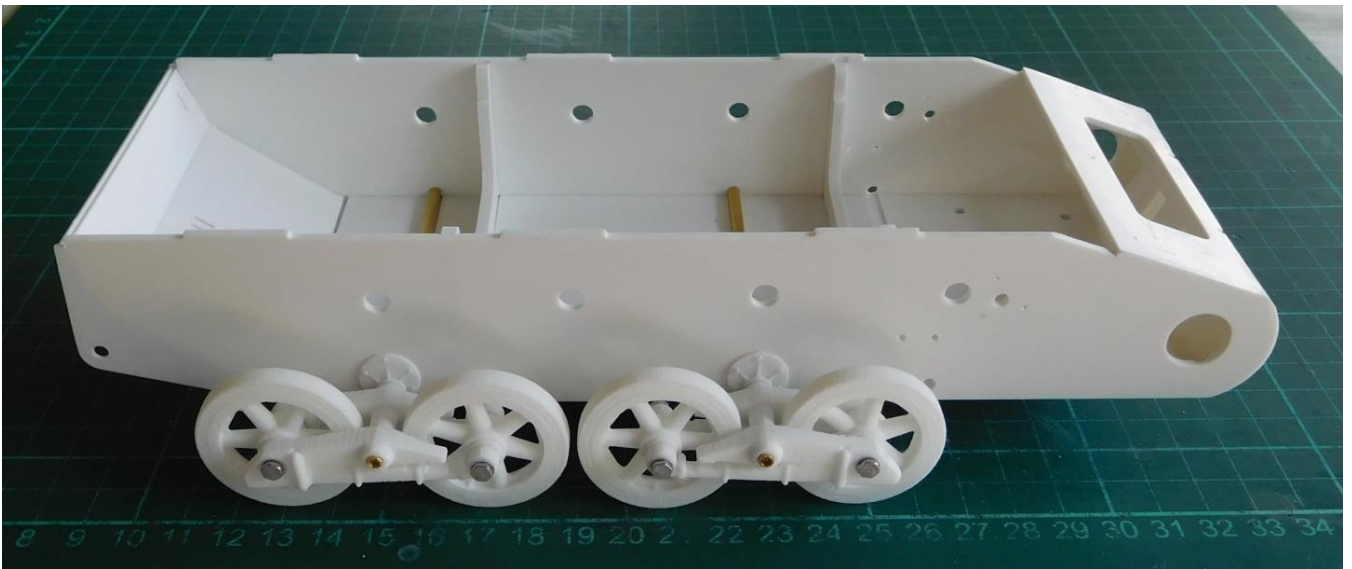
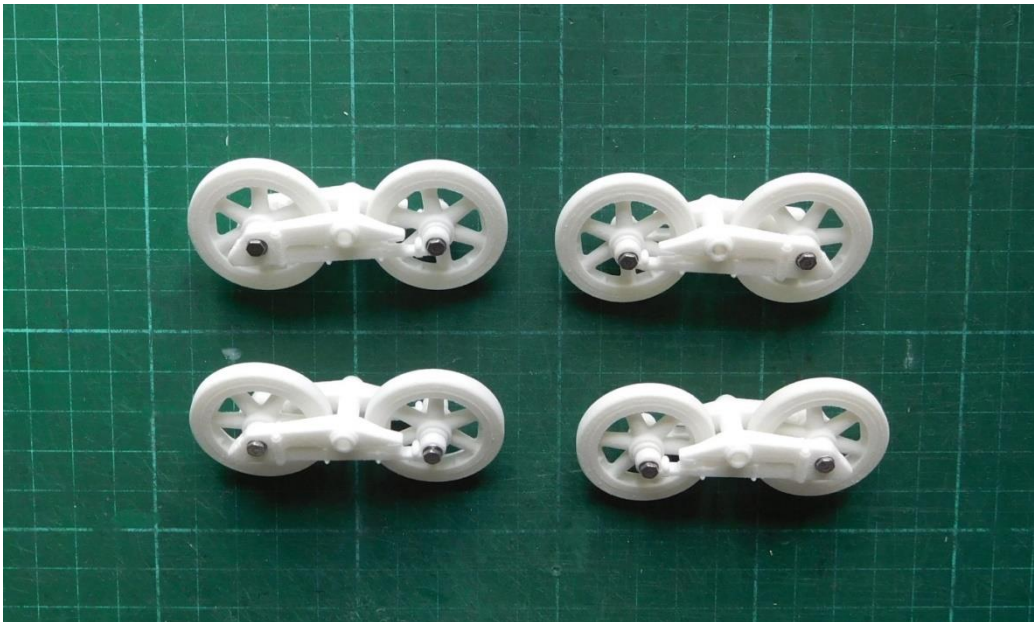
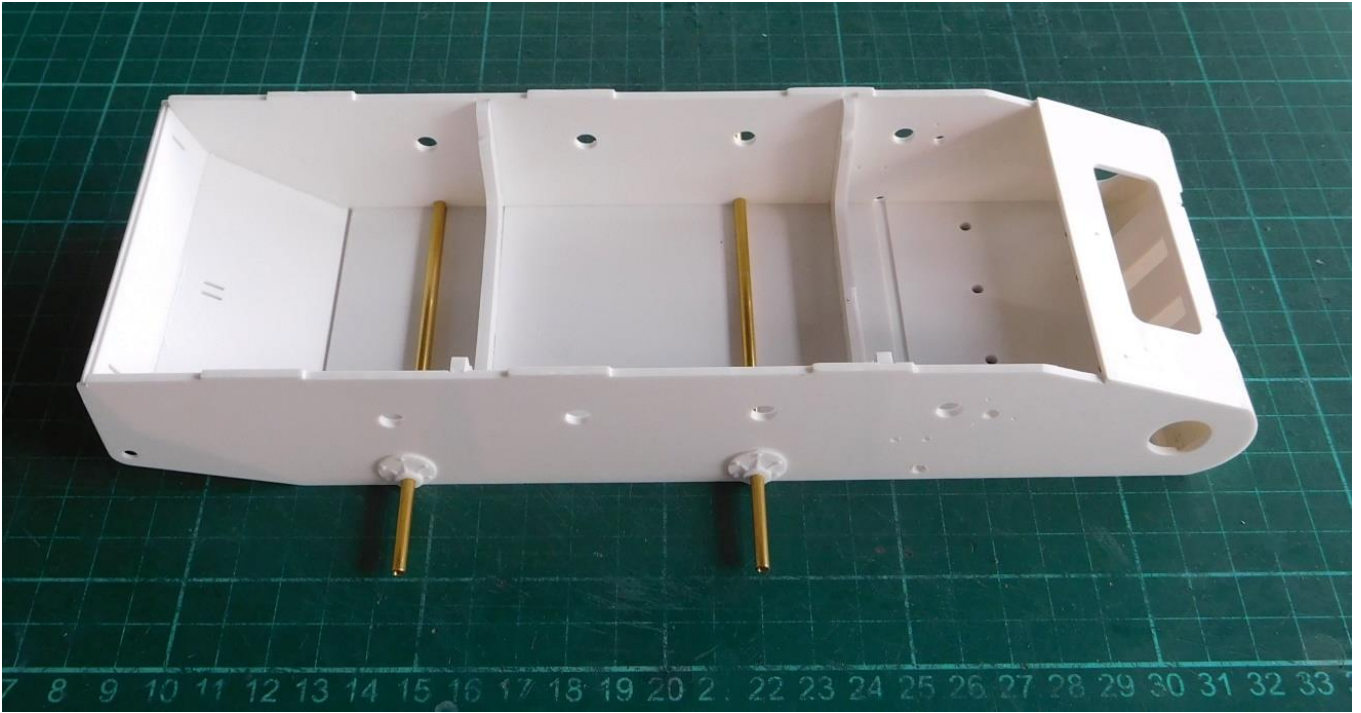

Vordere Laufrolle / front bogie

Druckfeder / spring
Ø0.5/Ø7.6x23mm

Messing-Rohr / brass pipe
Ø3.0/Ø2.1x97mm

Halbrundschraube /
half-round screw
M3x16

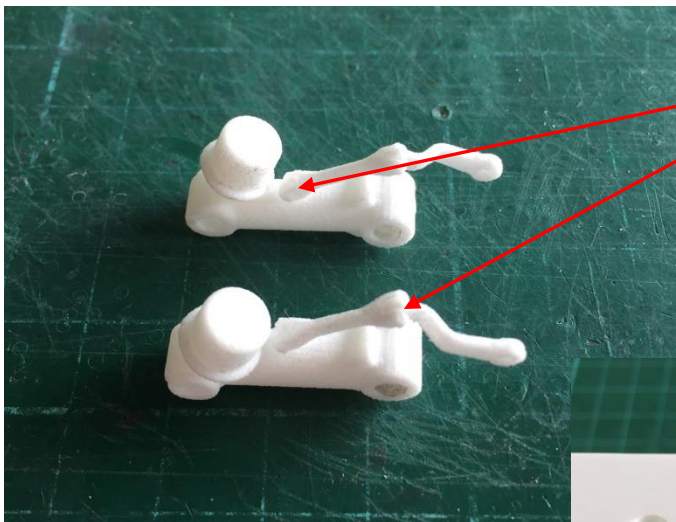
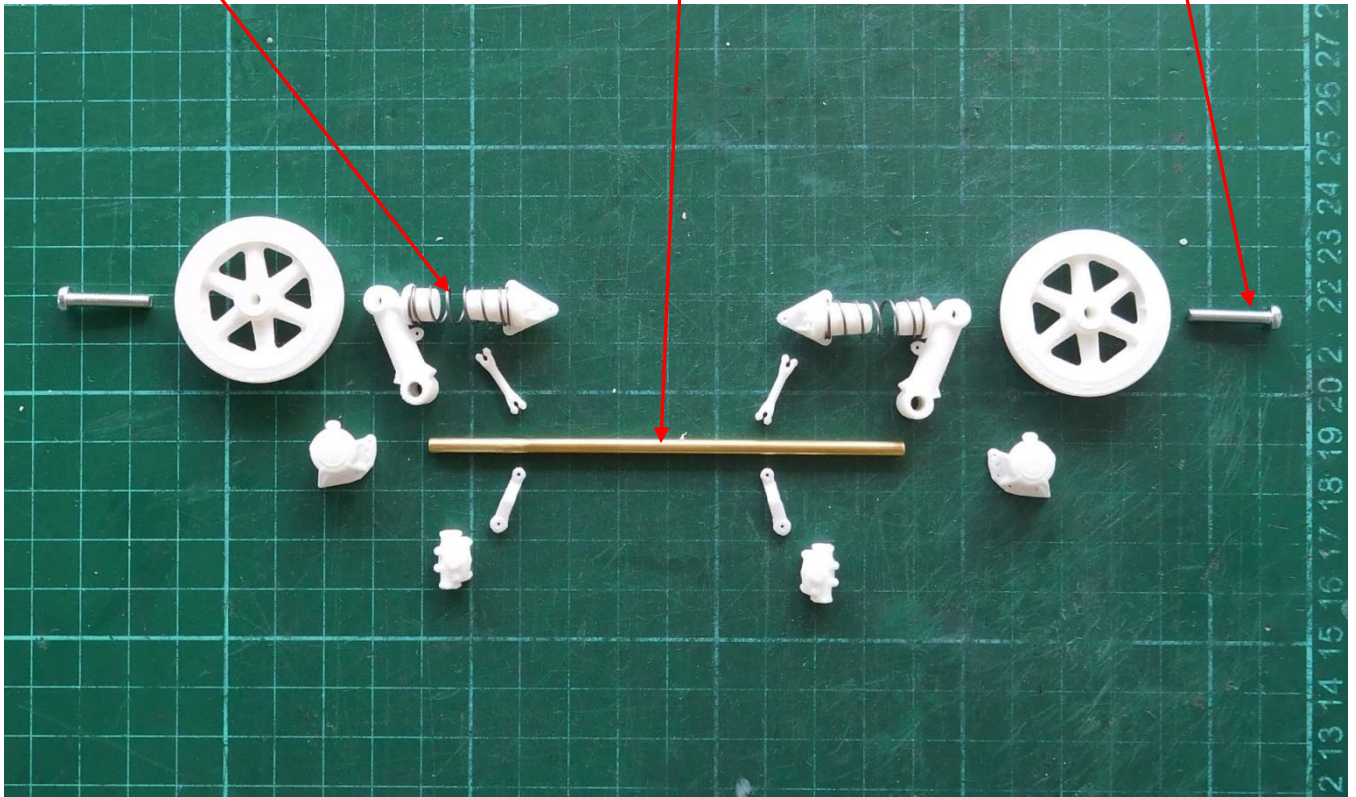

vorsichtig einklipsen –
nicht kleben! no glue!

6kt-Schraube / hex.
screw M1x8

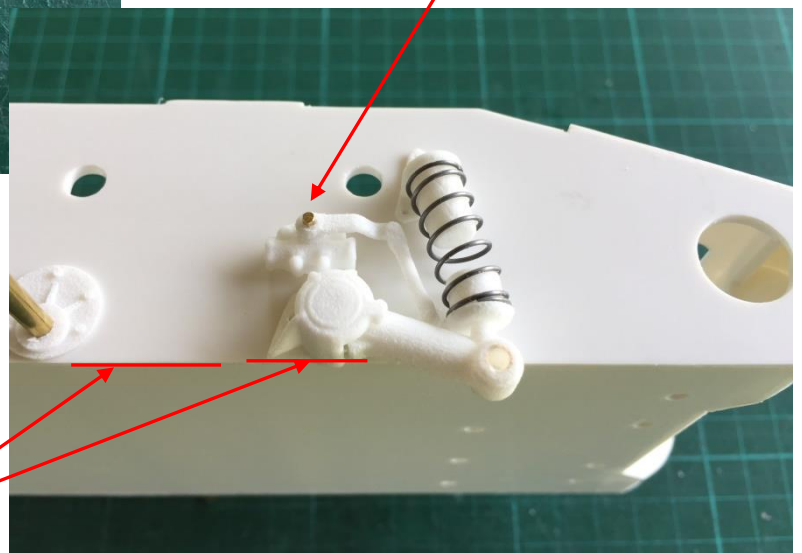

parallel

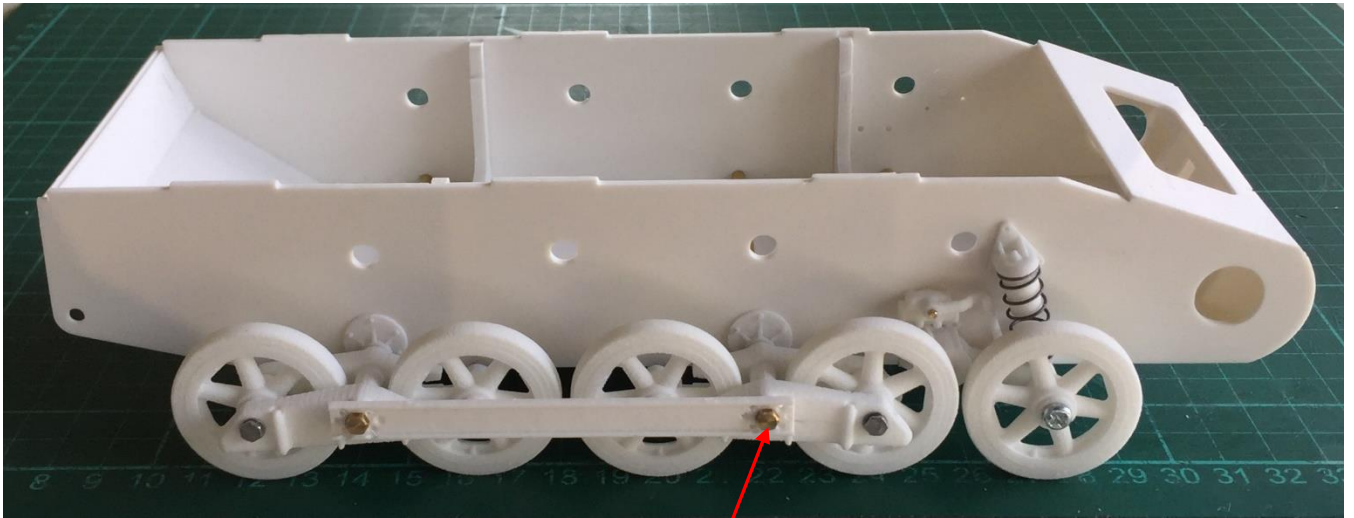

**6kt-Schraube in Messing-Rohr einkleben/
hex. screw M2x6 glued into brass pipe**

**Zyl.Schr. / Allen
screw M3x16**

**Zyl.Schrauben in Stützrollen einkleben (nicht in StR-Halter!)
/ screw glued into return roller (only!)**

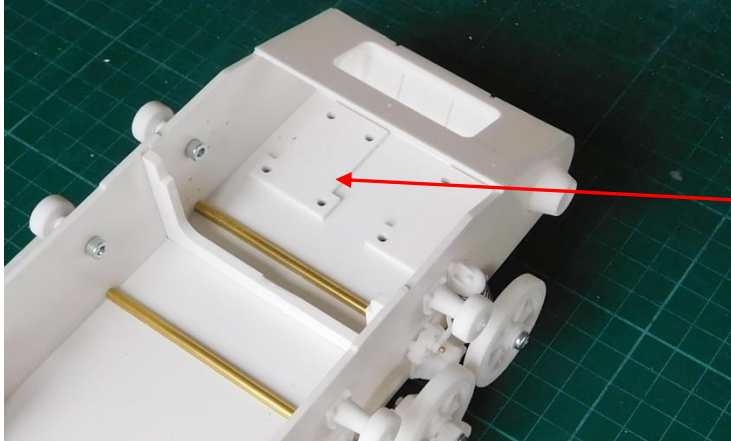
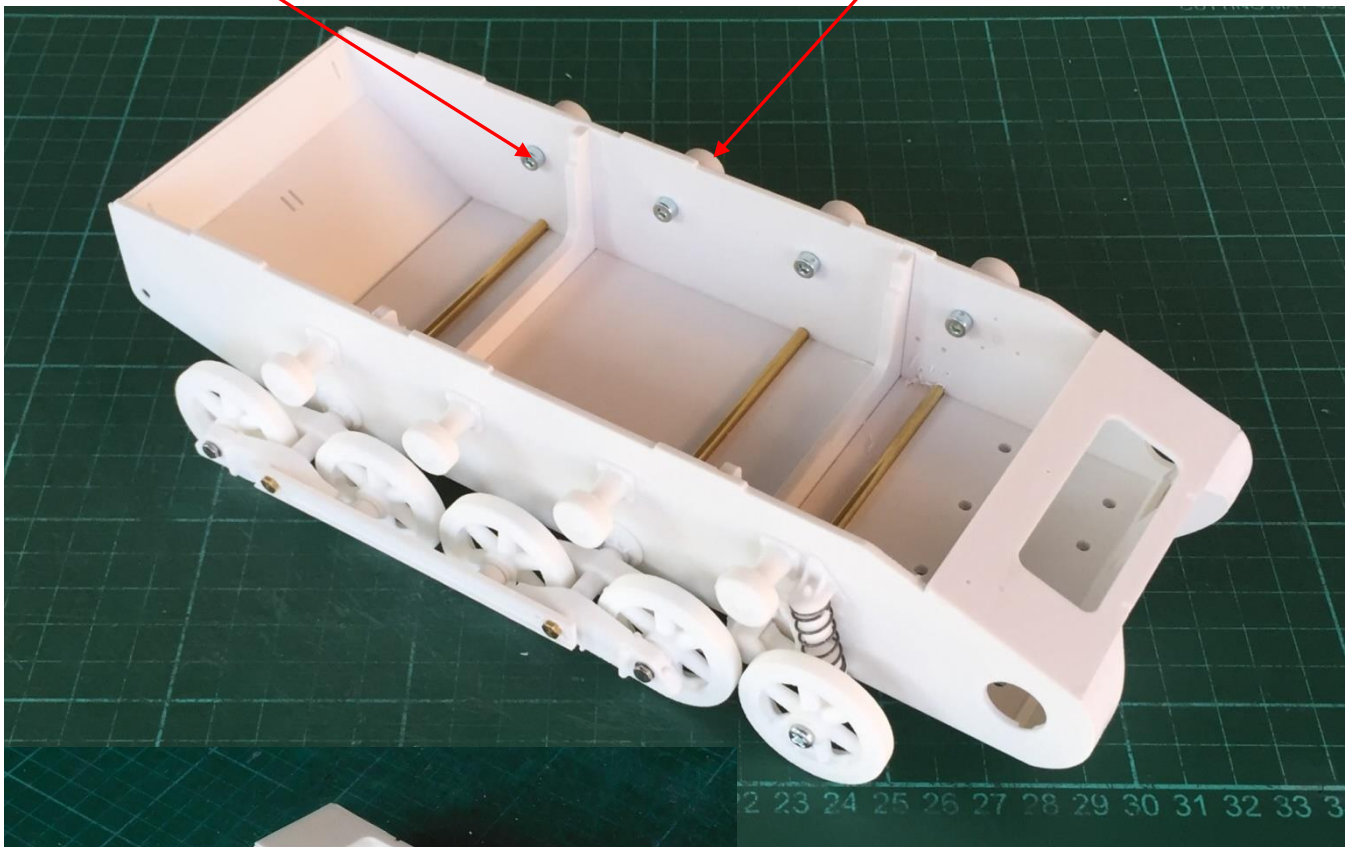

**Getriebeunterlagen /
track drives support**

Leitrad / idler mount

Messing-Rohr / brass pipe
Ø4.0/Ø3.1x78mm

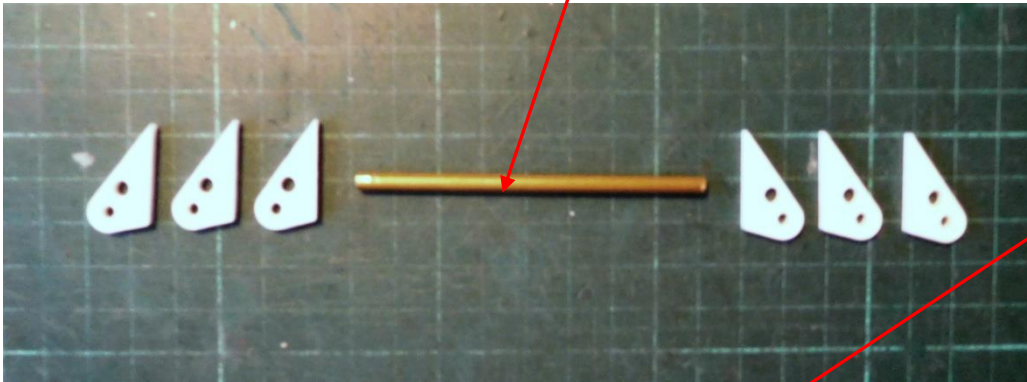

2 Stk. zusammenkleben / glueing 2 pcs.

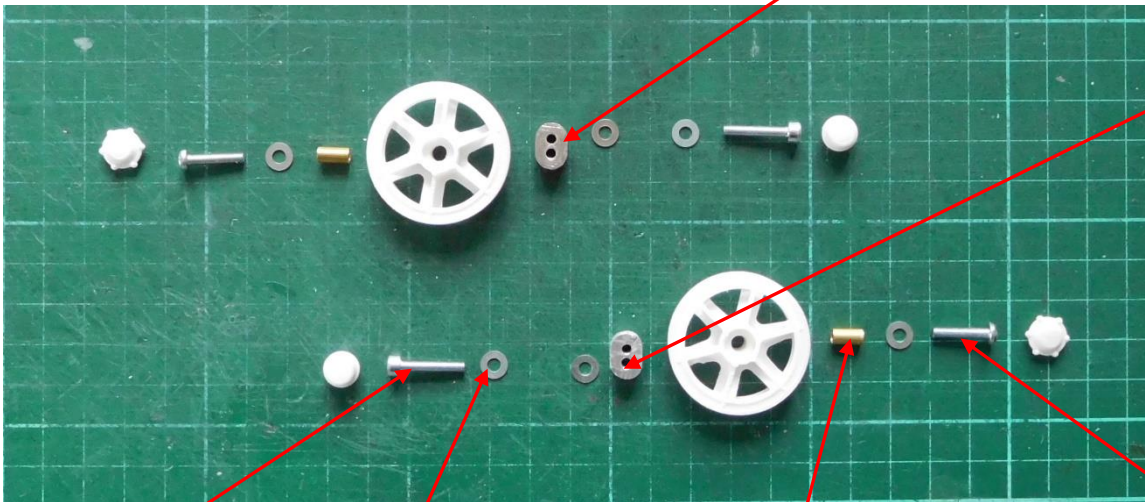

M3 Gewinde schneiden / rethreading M3 bore

Zyl.Schr. / Allen screw M3x16

U-Scheibe M3 / washer M3

Messing-Rohr / brass pipe Ø4.0/Ø3.1x7.5mm

Halbrundschaube / half-round screw M3x14

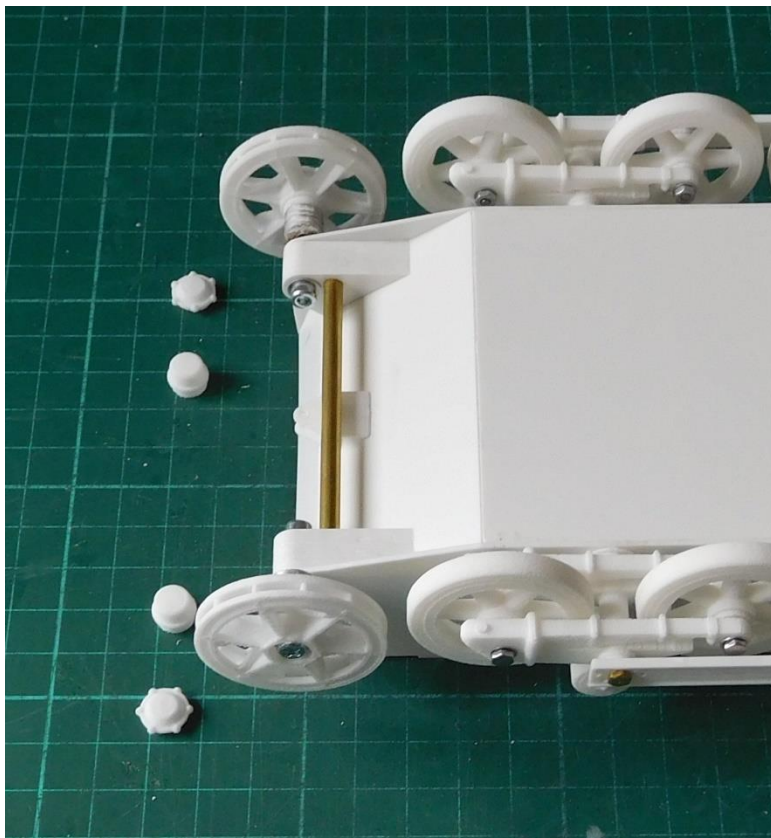

Kettenantrieb / track drive

**Getriebemotor / gear drive
Ø16, 12V, 400 RPM**

Halbrundschaube / half-round screw M2x6

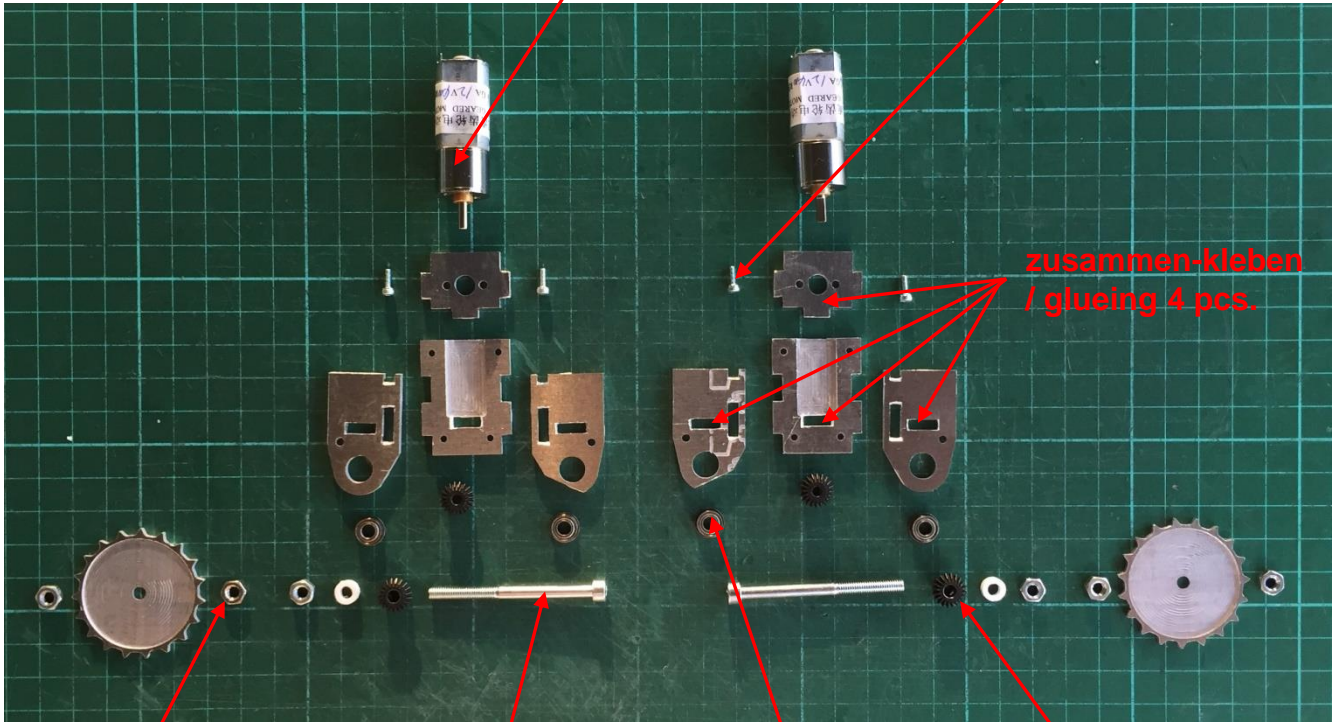

zusammen-kleben / glueing 4 pcs.

Mutter / nut M4

Zyl.Schr. / Allen screw M4x50

Bundlager / flange ball bearing Ø4/Ø8x3

Kegelradpaar / pinion m0.5 z20 b4 1:1

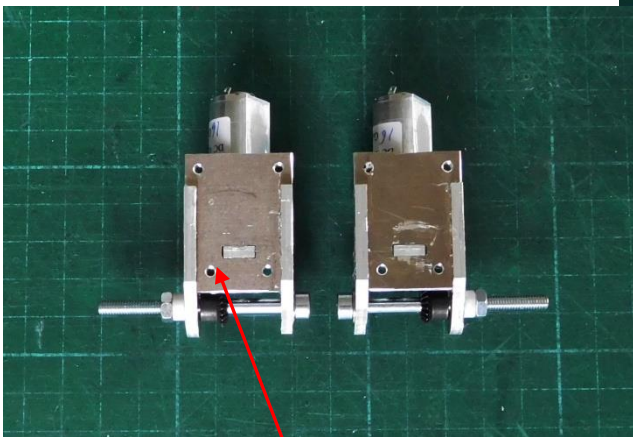

M2.5 oder M3 Gewinde schneiden / rethreading M2.5 or M3 bore

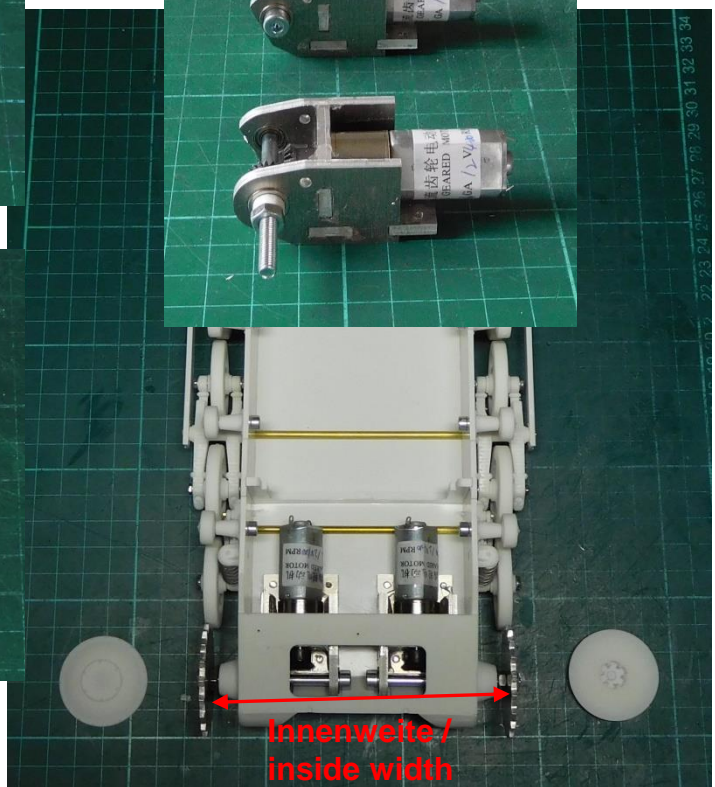

Innenweite / inside width 103mm

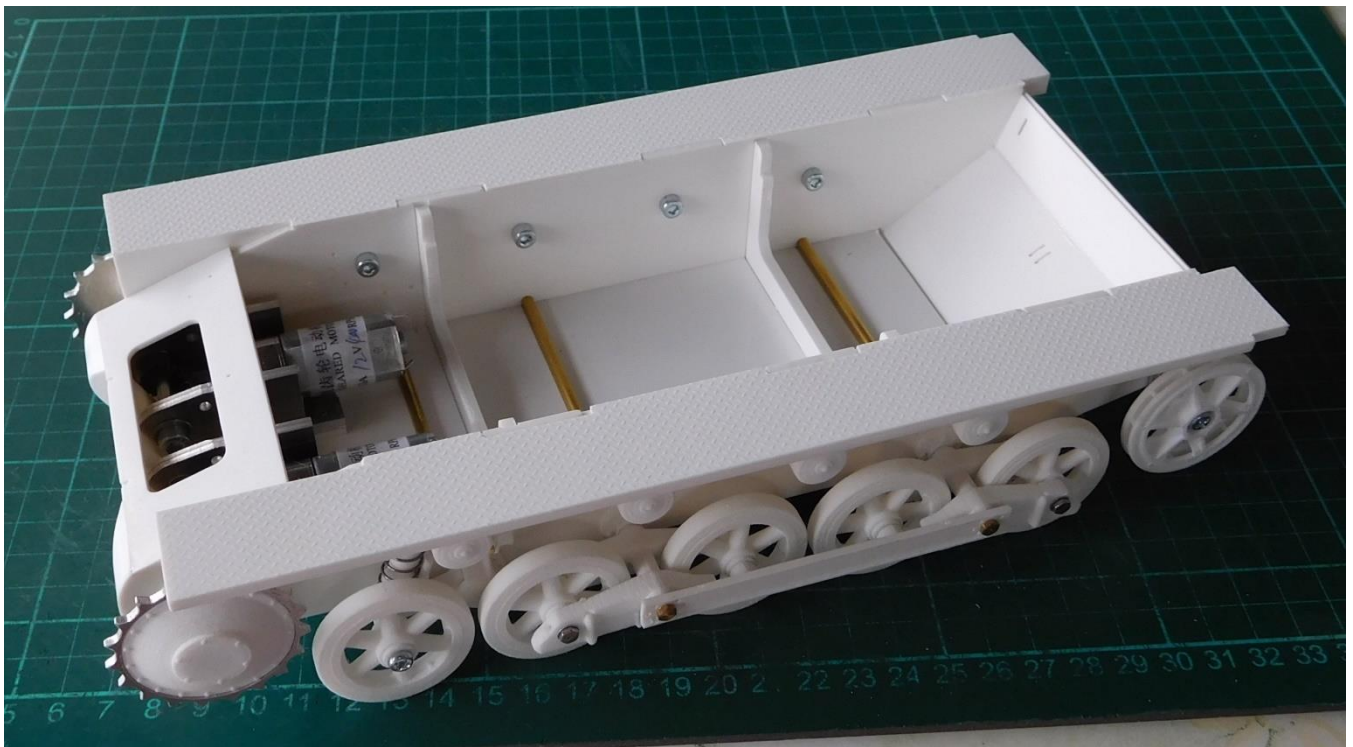
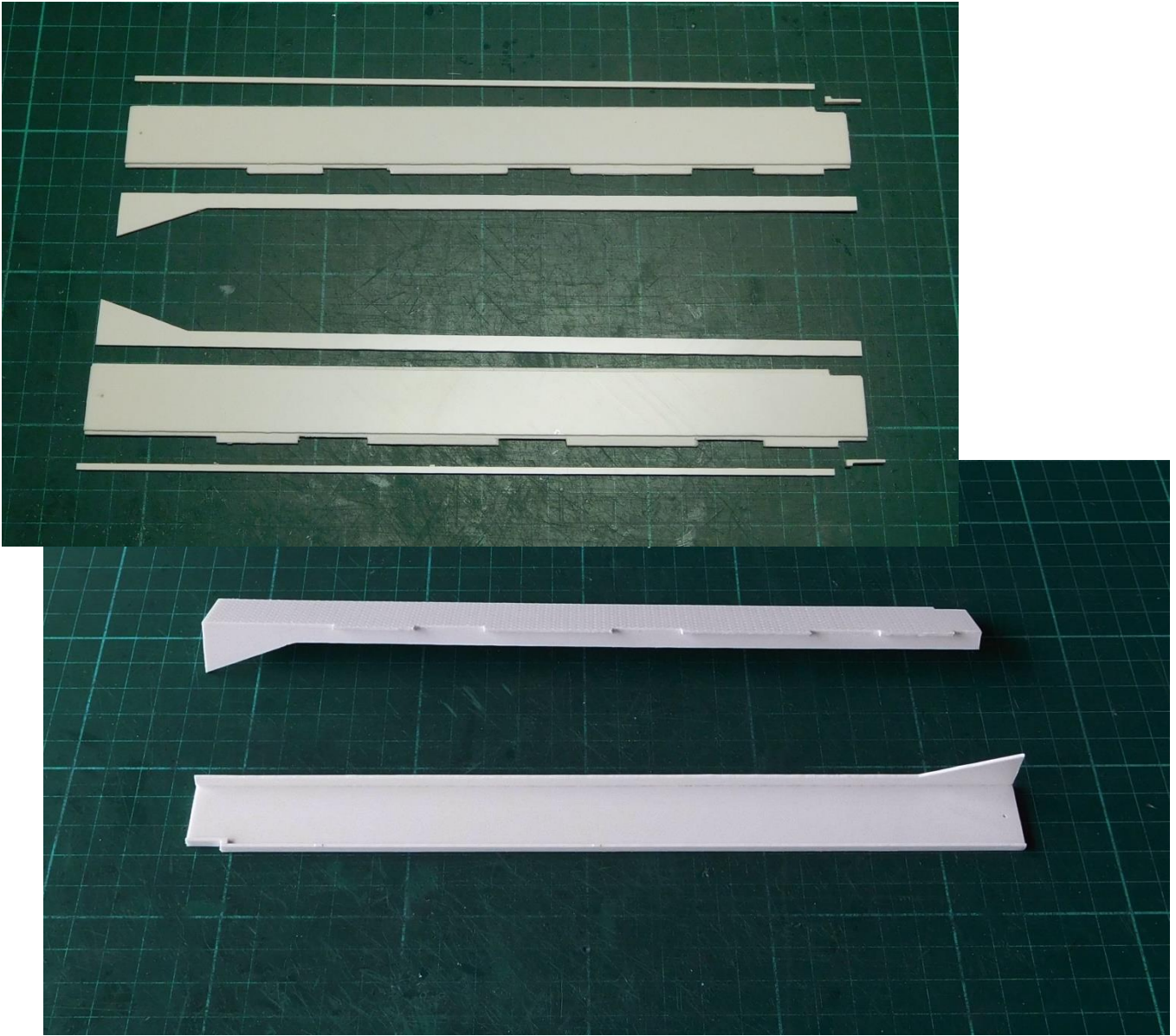

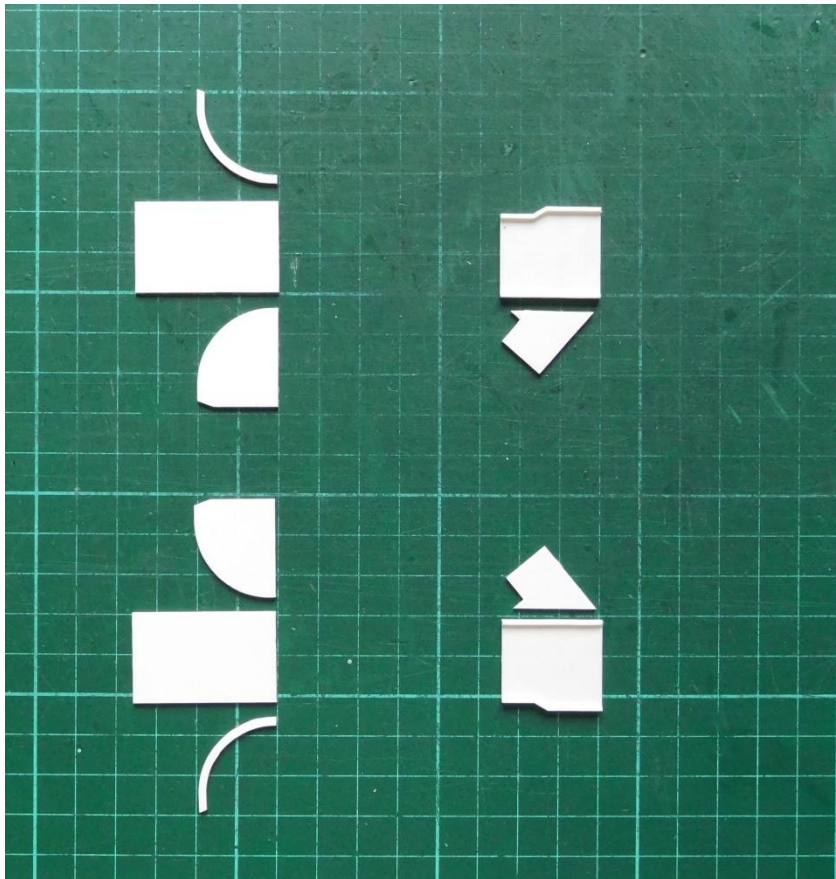

Fase / beveling

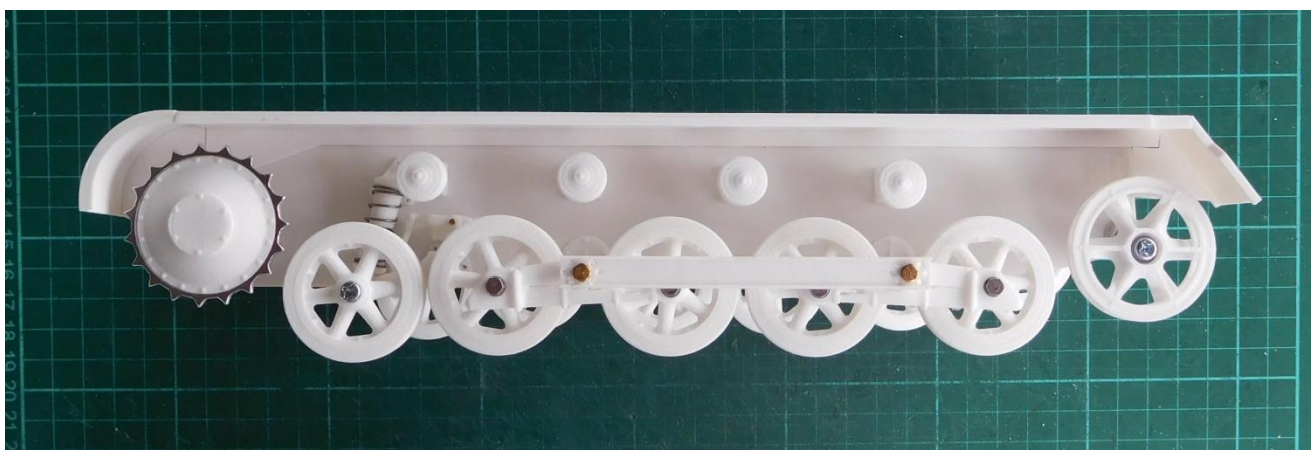
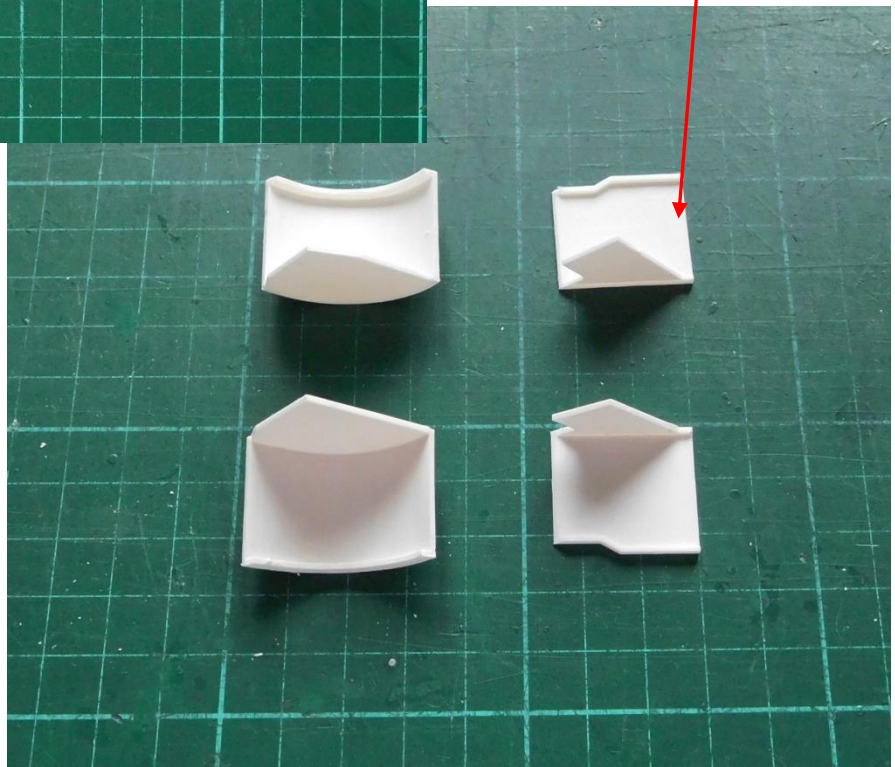

Oberwanne / upper hull

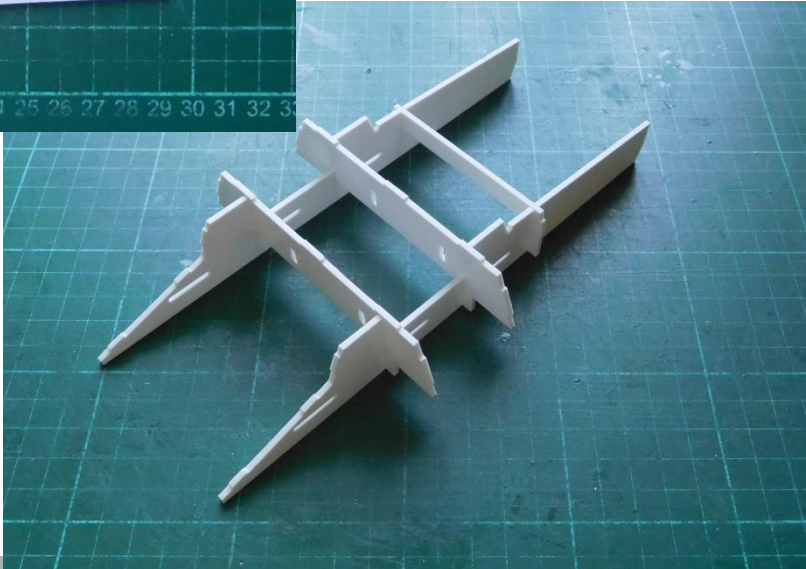
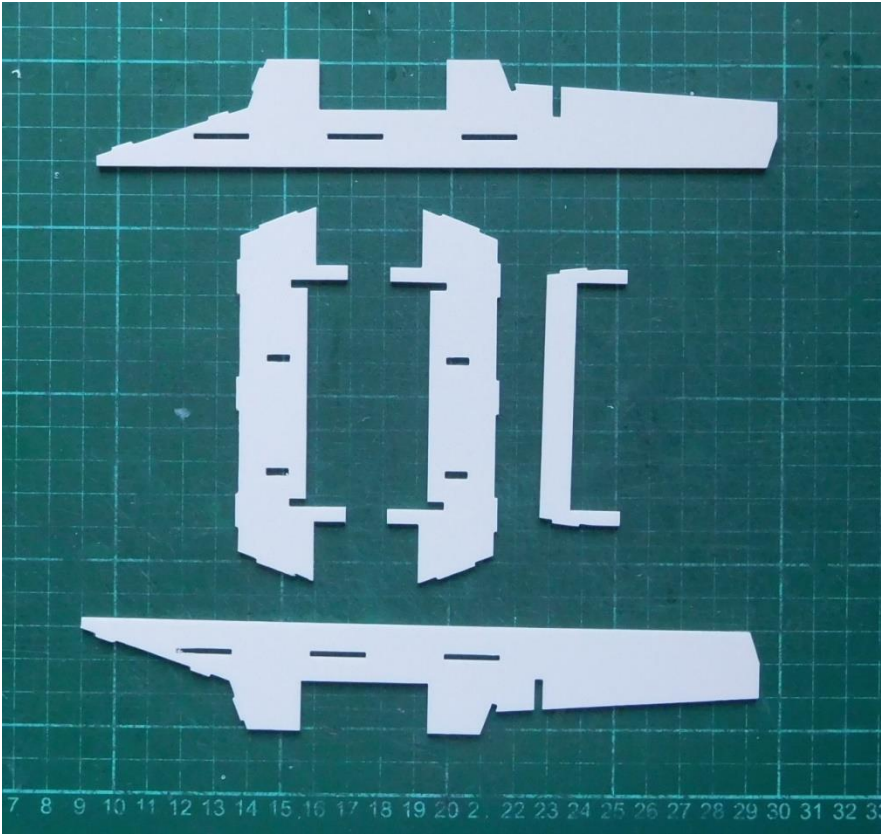

Fase /
beveling

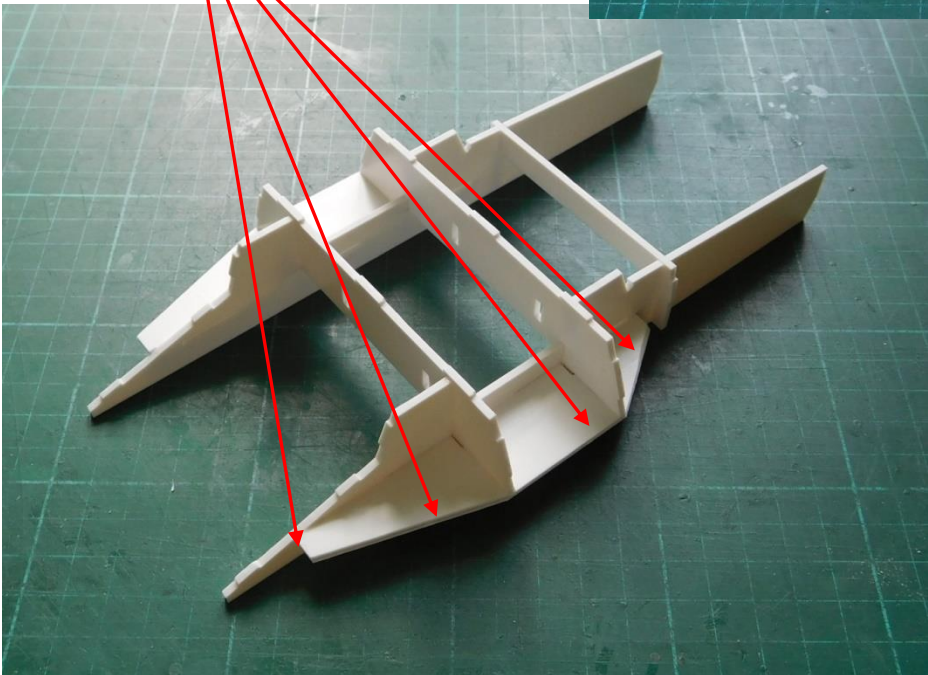

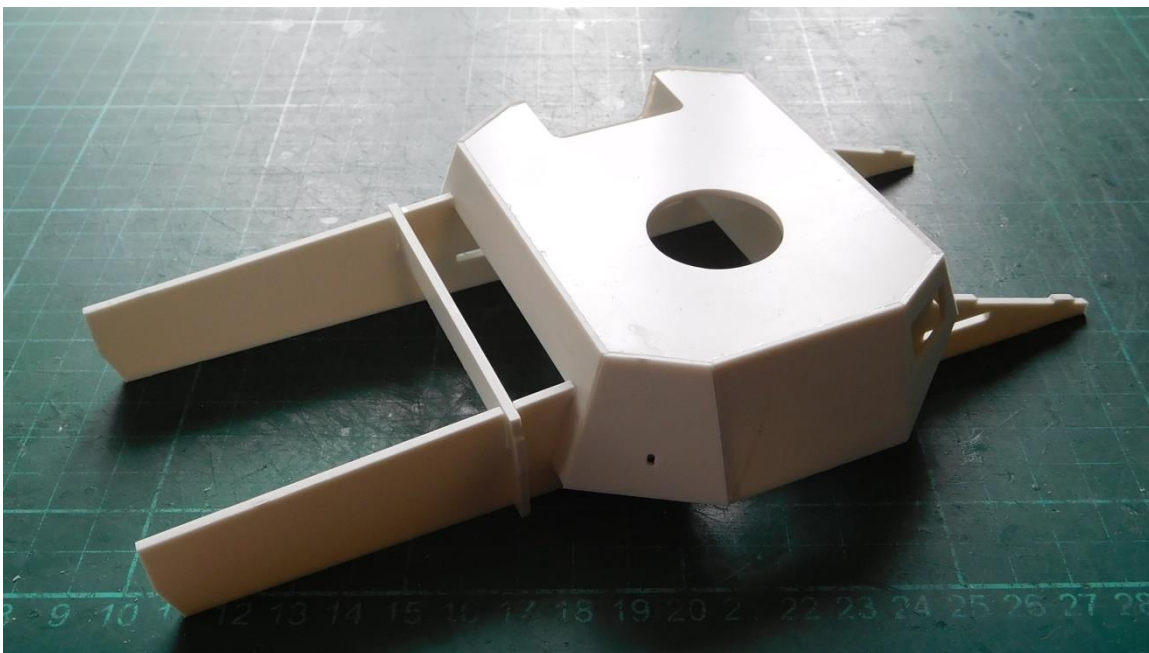
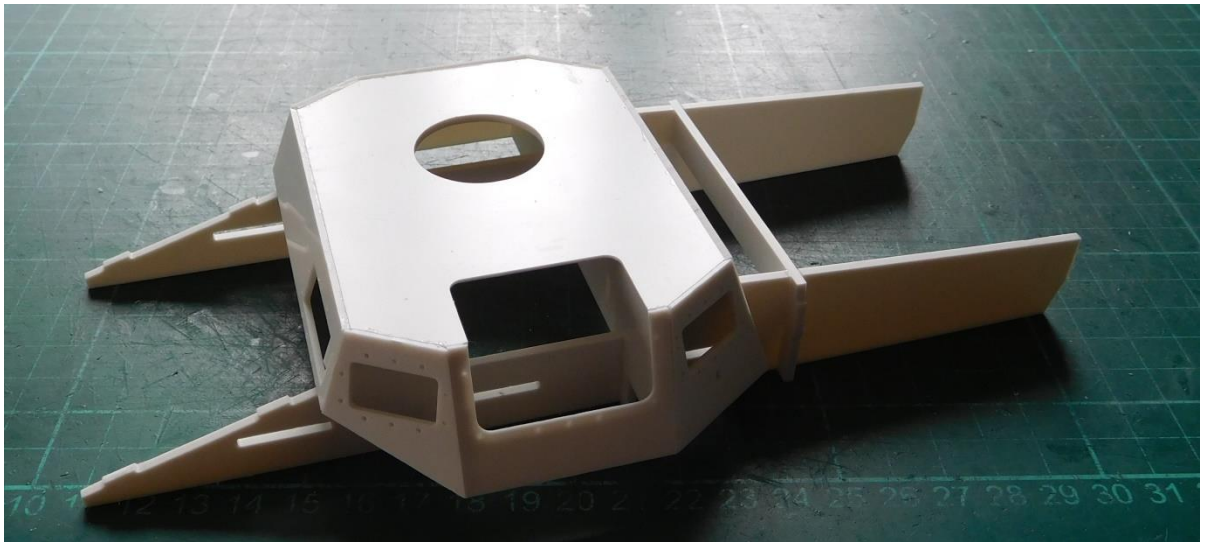
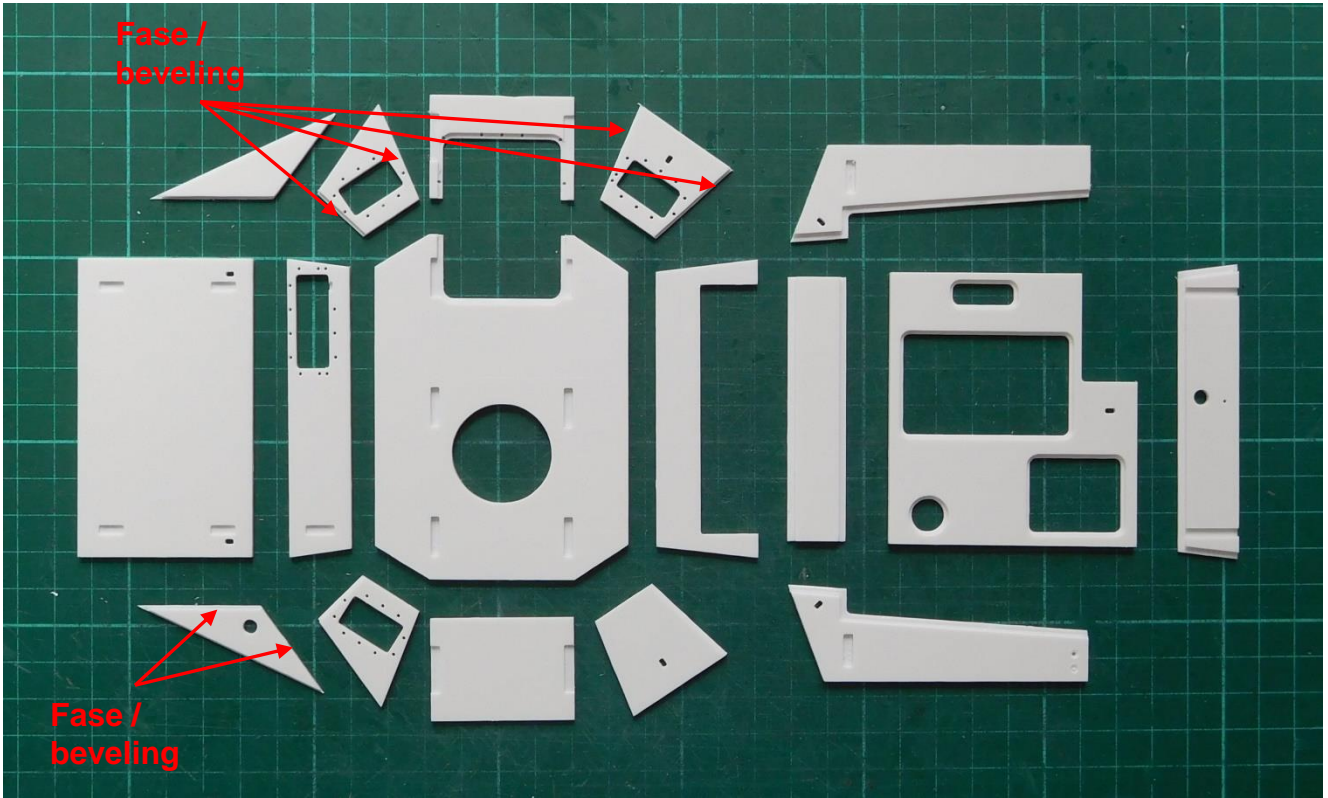

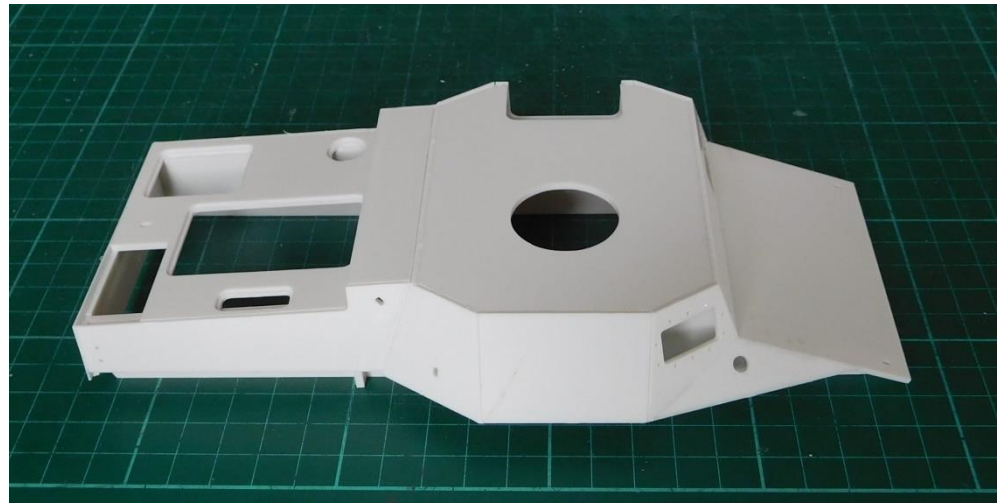
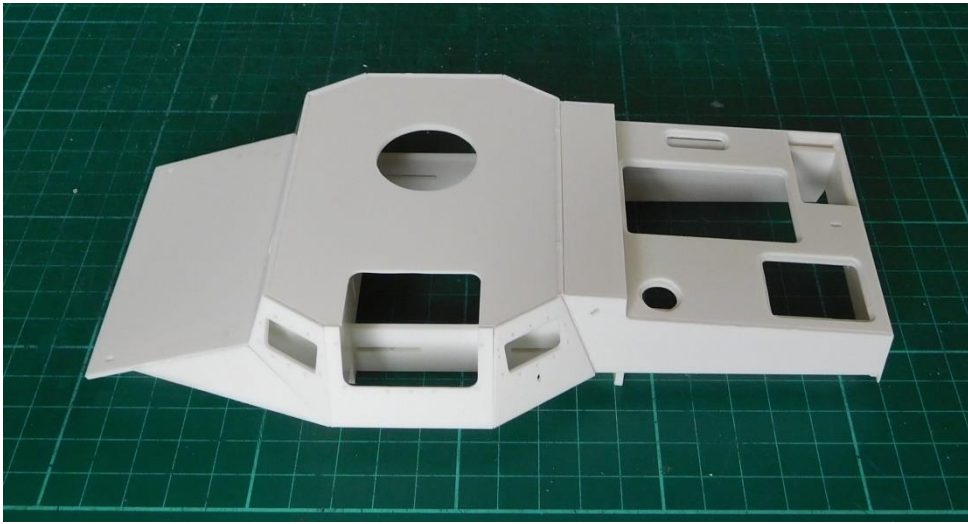

**Überstehende
Kanten flach-
schleifen bis zur
Deckplatten-
oberfläche /
grind to surface of
top panel**

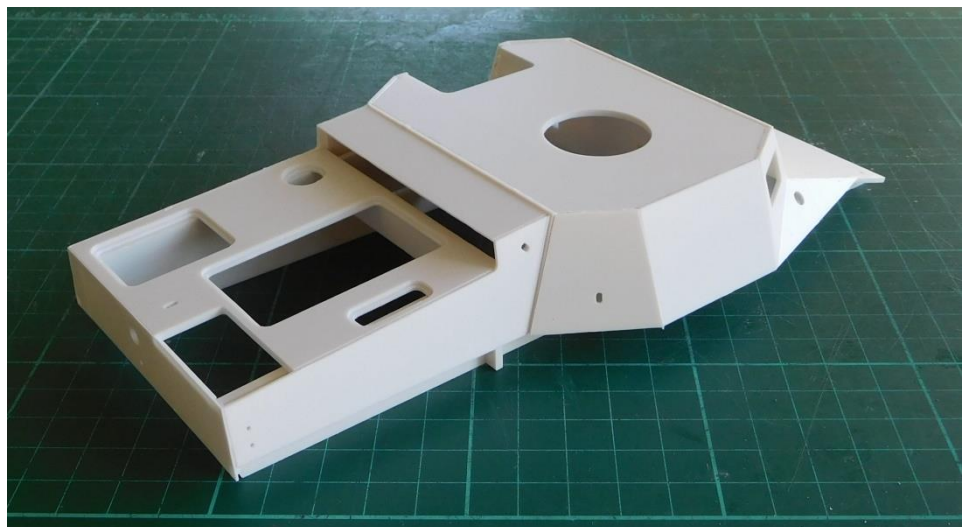
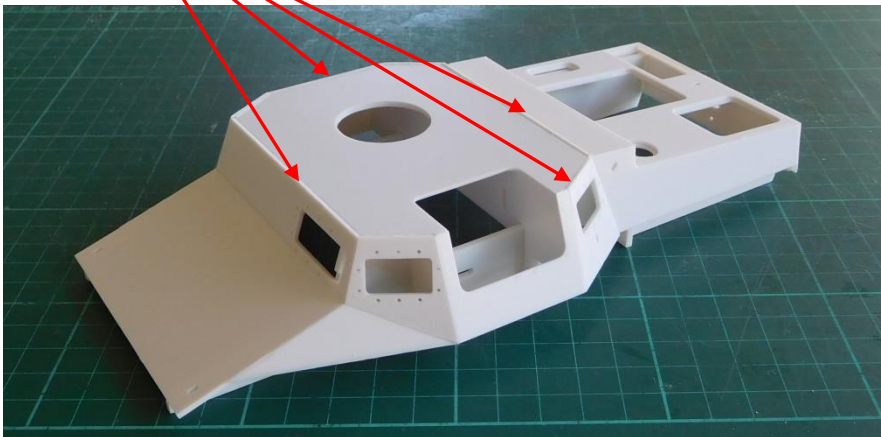

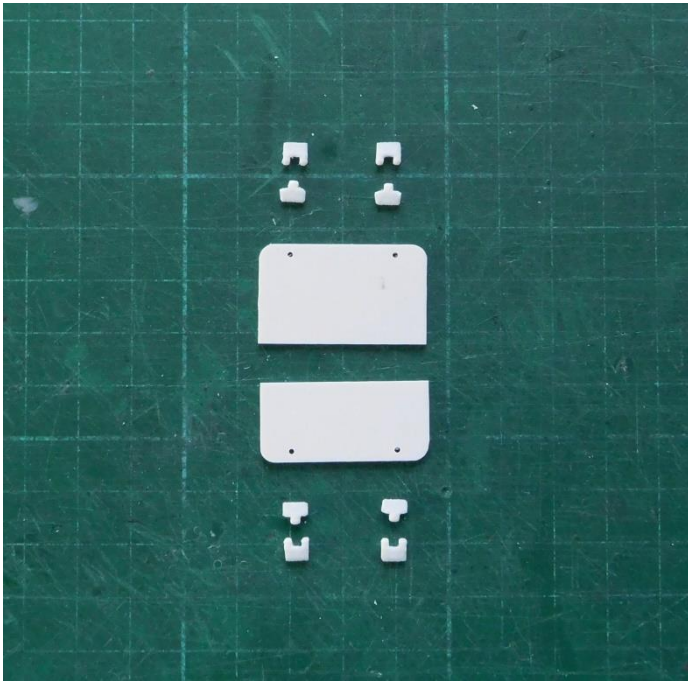

**Bohrung $\text{\O}0.5\text{mm}$ mit Aludraht
als Scharnierbolzen /
bore $\text{\O}0.5\text{mm}$ and hinge pin**

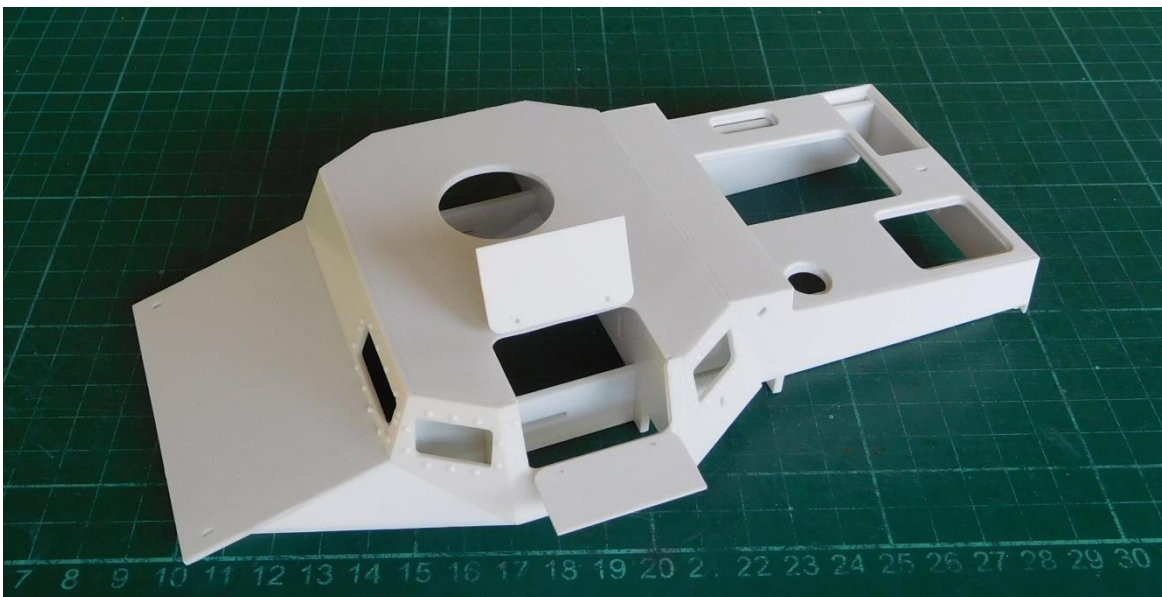
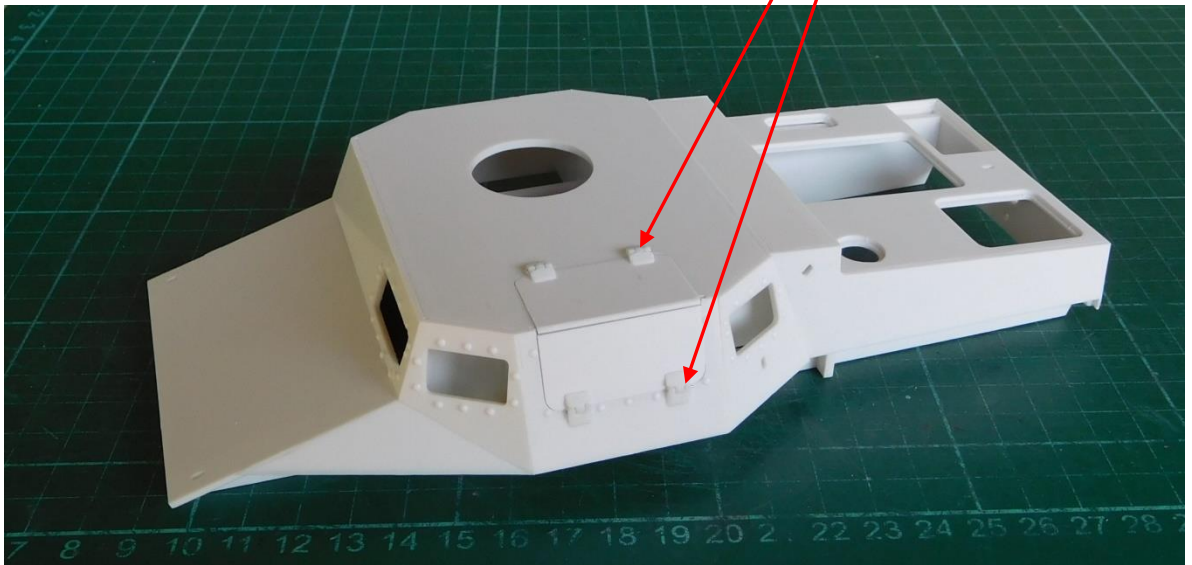

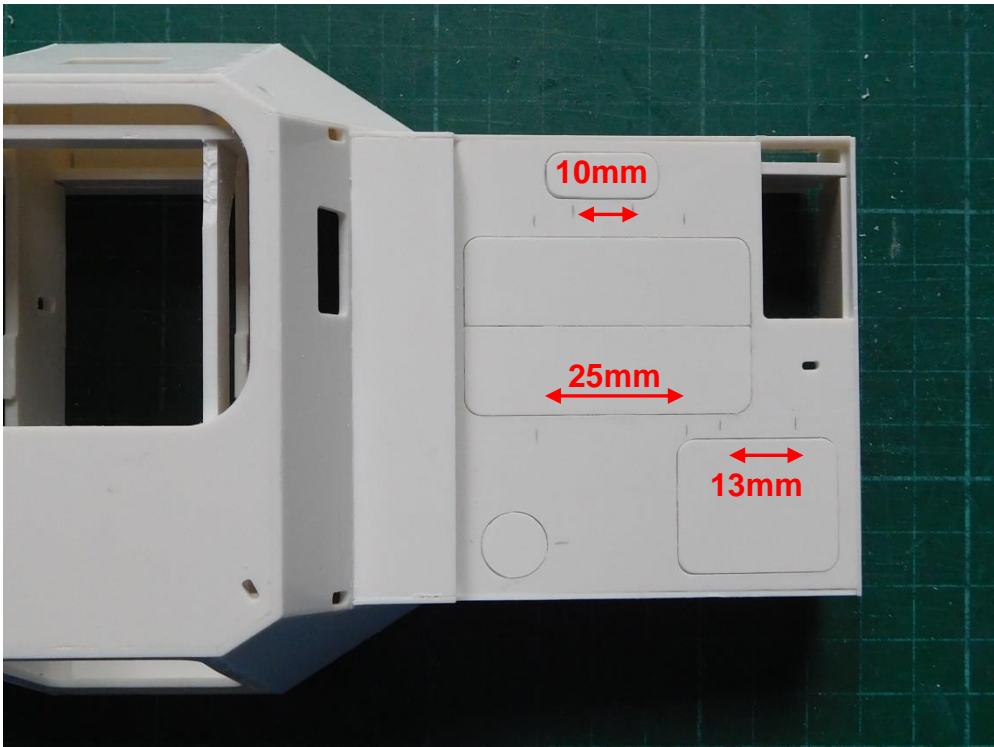

Oberwanne mit Luken
und Scharnieren
ergänzen

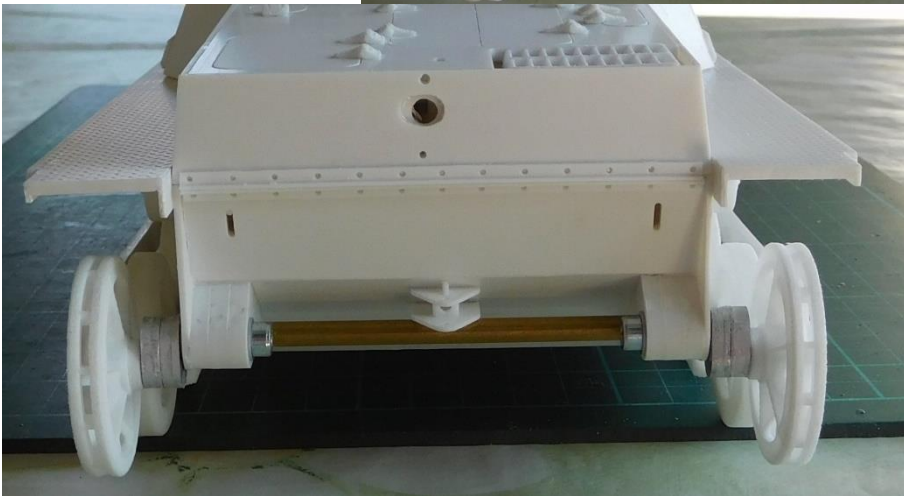
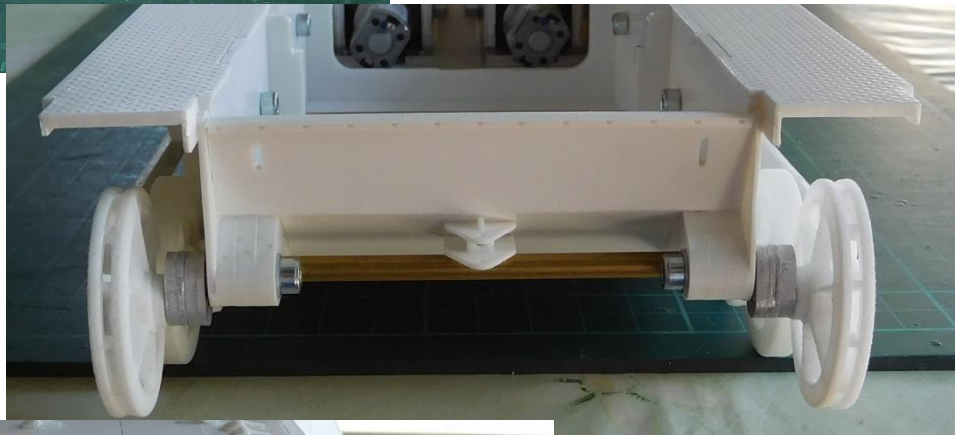

Auspuff / muffler

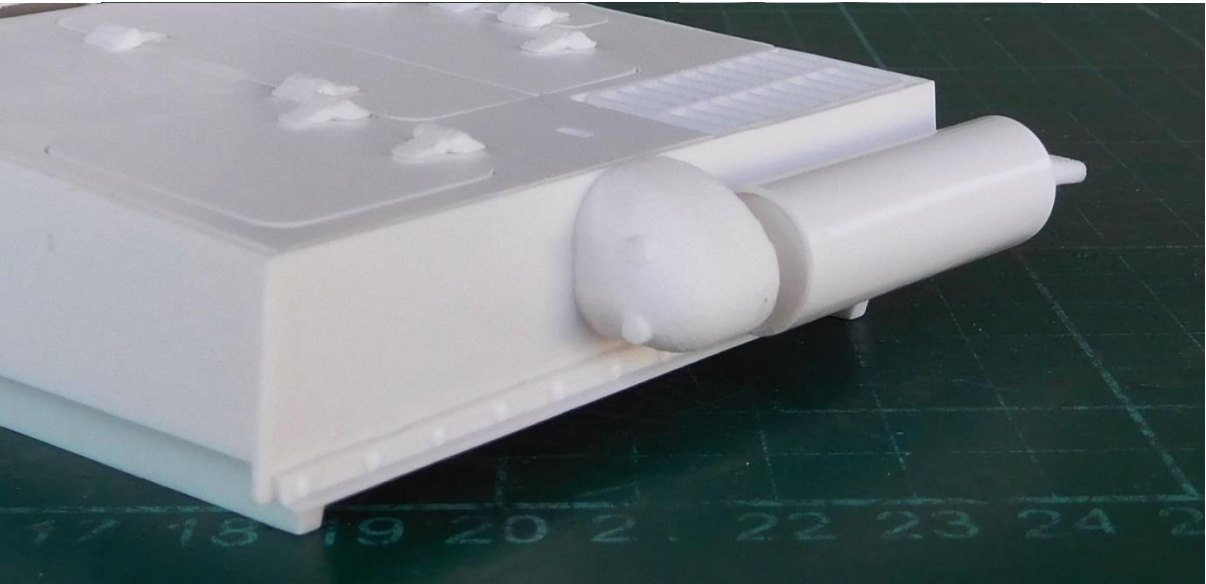
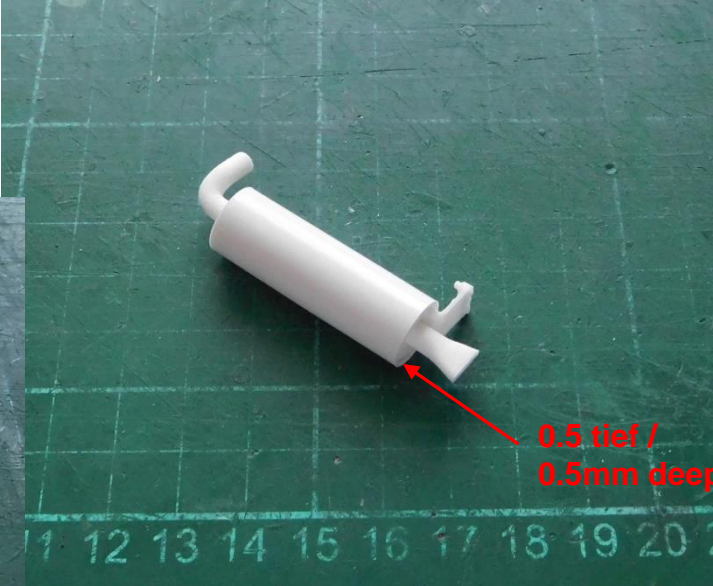
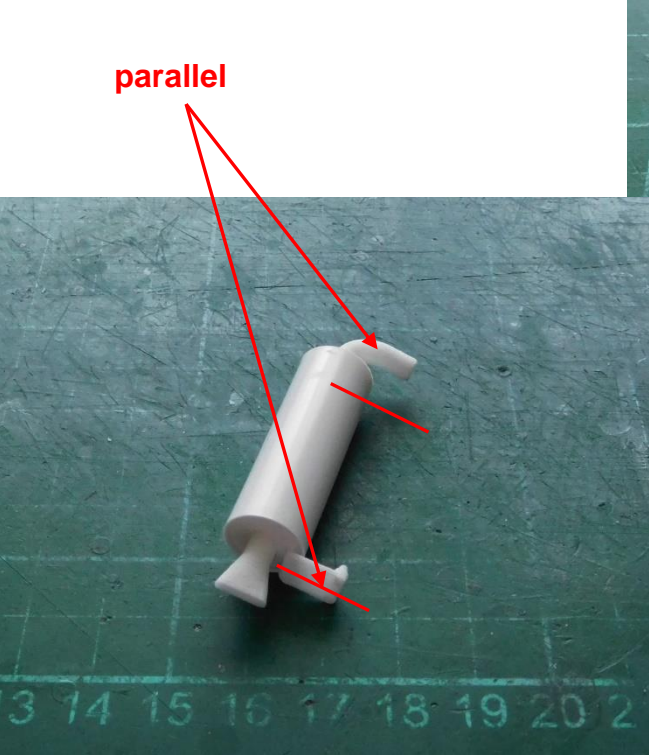
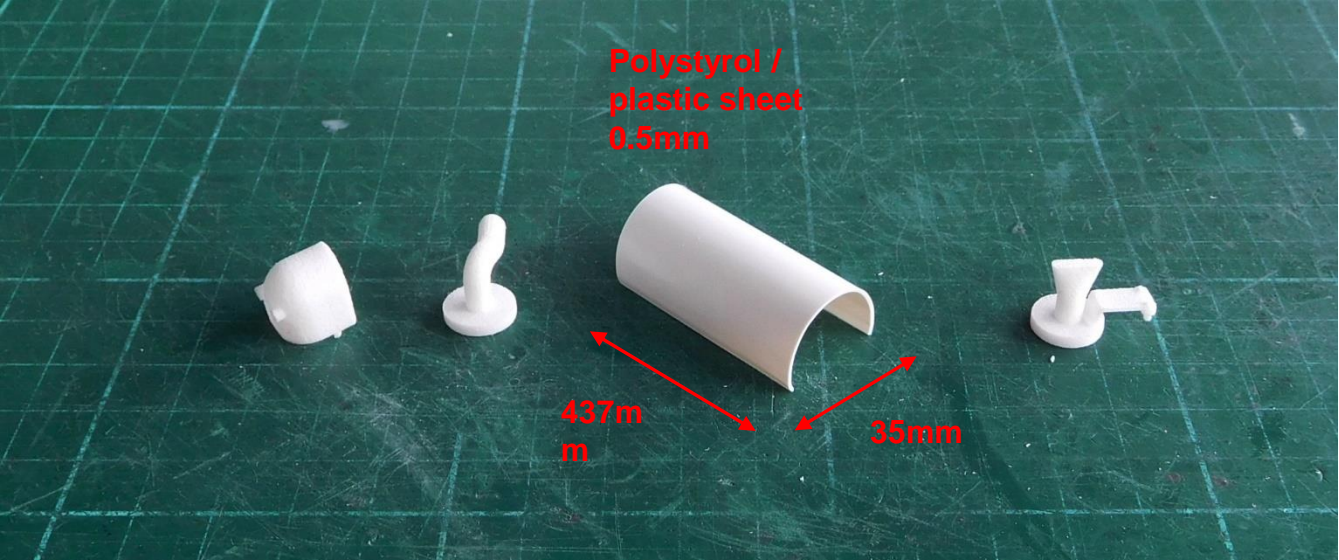

Turm / turret

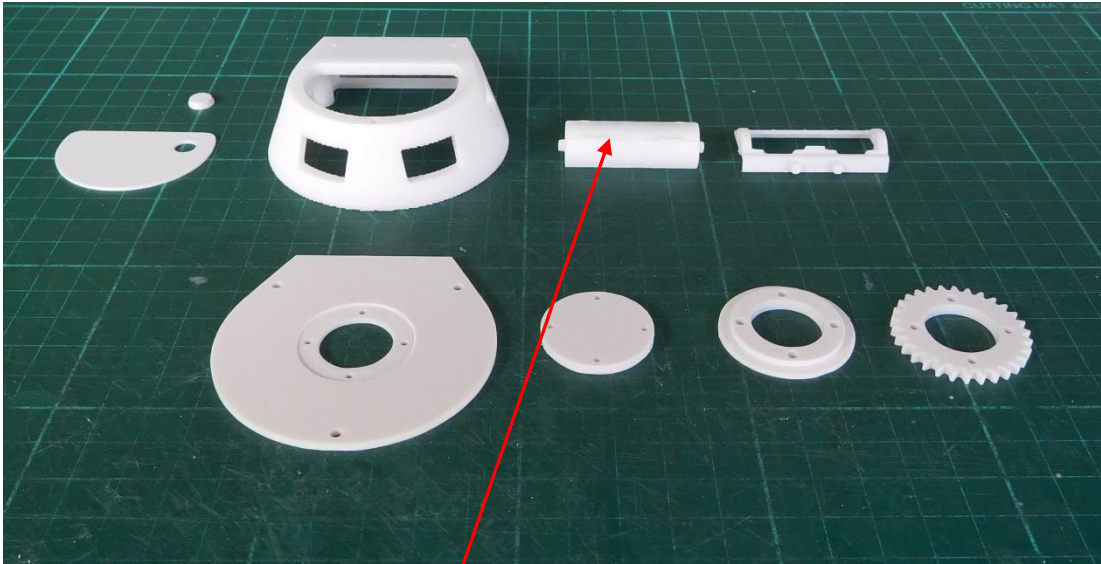

**nicht kleben!
no glue!**

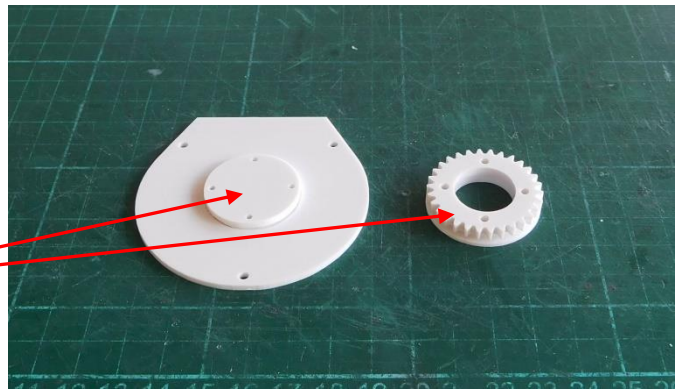

Bohrung Ø0.5mm mit Aludraht als Scharnierbolzen / bore Ø0.5mm and hinge pin

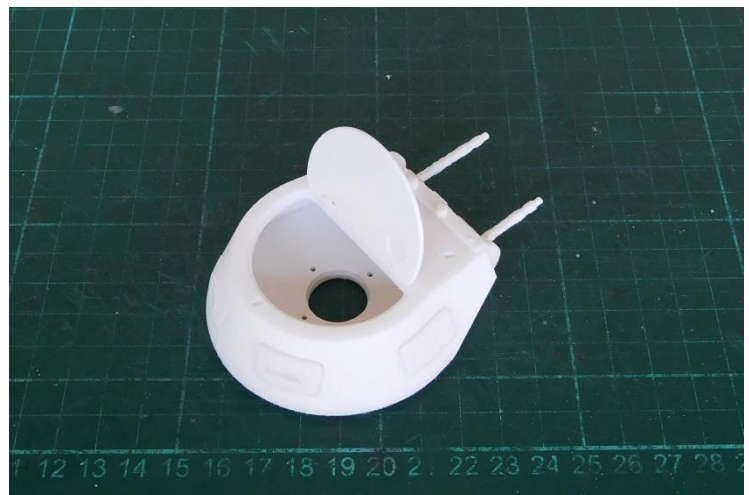

Fertigmodell einfügen

Fertigmodell einfügen